



**Load
Runners®**

**HEAVY-DUTY
IDLER ROLLER &
RAIL SOLUTIONS**

OSBORN WORLDWIDE



GLOBAL REACH. LOCAL SUPPORT.

Osborn designed the world's first non-needle roller bearing idler roller more than fifty years ago to solve an internal manufacturing challenge on the company's foundry equipment. Today, Load Runners is the world's leading idler-roller and rail solution, used in numerous industries from healthcare and primary metals to automotive and general industry.

Osborn is the global leader in surface treatment and finishing solutions, with more patents on products and processes than all other brush companies combined. Established in 1887 in Cleveland, Ohio, U.S.A., Osborn's innovative culture has produced numerous industry firsts --- including Load Runners® brand precision load-handling systems.

Locations

Brazil

Osborn International Ltda.
Rua Lemos Torres,
150 - Jardim Gagliardi
09890-070 São Bernardo do Campo
Brazil
Tel.: +55 1143916559
Fax: +55 1143916550
email: brsales@osborn.com

China

Osborn International
Rm. 505, Tower H Huiyuan Int. Apartment
No. 8 Beichen East Road,
Chaoyang District
Beijing, 100101 China
Tel.: +86 1084988191
Fax: +86 1064991863
email: cnsales@osborn.com

France

Osborn Unipol S.A.
Parc d'Activités Les Doucettes
23 Avenue des Morillons
95140 Garges Les Gonesse
Paris, France
tel: +33 134450600
fax: +33 139936711
email: frsales@osborn.com

Germany

Osborn International GmbH
Ringstrasse 10
35099 Burgwald, Germany
tel: (011) 49 64 51 5 88-0
fax: (011) 49 64 51 5 88 2 06
email: desales@osborn.com

Mexico

Osborn
Emilio Cárdenas No. 211
Centro Industrial Tlalnepantla
Tlalnepantla Edo. México, 54030
tel: +52 5555659555
email: mxsales@osborn.com

Portugal

Osborn Unipol Lda
Rua de Pardelhas
4805-062 Brito-Guimarães
Portugal
Tel.: +351 253479550
Fax: +351 253576629
email: ptsales@osborn.com

Romania

Osborn International SRL
Bd. Bucovina, Nr. 151
725300 Gura Humorului, jud.
Suceava, Romania
tel: +40 230234212
fax: +40 230531785
email: rosales@osborn.com

Spain

Osborn - Unipol, S.L.
C/O Ronda Norte, 320
(Poligono Industrial) - Apartado 169
46470 Catarroja (Valencia)
Spain
Tel.: +34 961325876
Fax: +34 961324602
email: essales@osborn.es

Sweden

Osborn International AB
Huskvarnavagen 105, Box 244
56123 Huskvarna, Sweden
tel: (011) 46 36 38 92 00
fax: (011) 46 36 14 43 49
email: swsales@osborn.com

U.K.

Osborn Unipol (UK) Limited
Avenue West
Newhouse Farm Industrial Estate
Chepstow NP16 6UD U.K.
Tel.: +44 1291643200
Fax: +44 1291643298
email: sales@osborn-unipol.co.uk

U.S.

Osborn
1100 Resource Drive, Suite 1
Brooklyn Heights, OH 44131
U.S.
tel: +1 2163611900
fax: +1 2163611913
email: rollers@osborn.com

Anywhere/Any time

www.LOADRUNNERS.com

TABLE OF CONTENTS

Load Runners

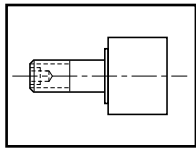

Plain Concentric Stud Style
Inch, pages 30-31
Metric, pages 62-63

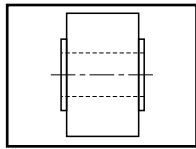

Plain Yoke Style
Inch, page 56
Metric, page 74
Crown Yoke Style
Inch, page 57

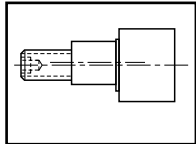

Plain Eccentric Stud Style
Inch, pages 32-33
Metric, pages 64-65

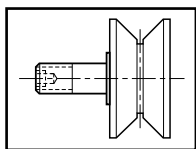

V-Grooved Concentric Stud Style
Inch, pages 38-39
Metric, pages 70-71

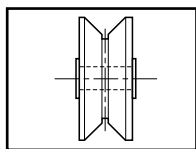

V-Grooved Yoke Style
Inch, page 59
Metric, page 76

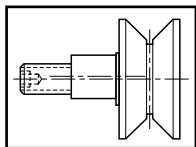

V-Grooved Eccentric Stud Style
Inch, pages 40-41
Metric, pages 72-73

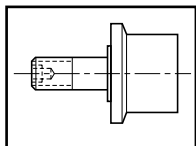

Flanged Concentric Stud Style
Inch, pages 34-35
Metric, pages 66-67

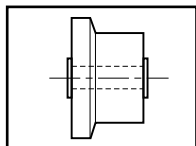

Flanged Yoke Style
Inch, page 58
Metric, page 75

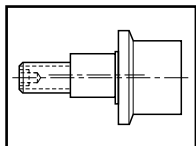

Flanged Eccentric Stud Style
Inch, pages 36-37
Metric, pages 68-69

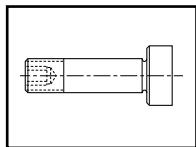

Heavy Duty Yoke Shafts
Inch, pages 60-61
Metric, page 77

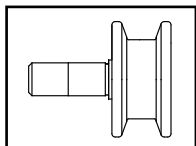

Double-Flanged Concentric Stud Style
Inch, page 44-45

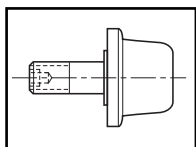

Flanged Crown Concentric & Eccentric
Inch, page 42-43

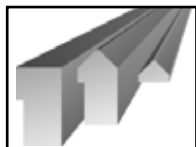

Load Rails
pages 11-12

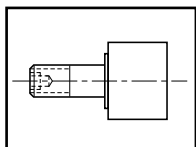

CAM RUNNER®
Pages 78-79



Load Runners for Special Applications
Inch, pages 46-55
• *Stainless*, p.46-59
• *High-Temp*, p.50-51
• *Nylon*, p.52-53
• *Urethane*, p.54-55

Product Information 4-10

Load Rails® and Track Requirements 11-12

Industry Spotlights 13-28

Primary Metals	14-15
Oilfield and Petrochemical	16-17
Automotive	18-19
Off-Highway	20-21
Aggregate and Mining	22-23
Kinetic Architecture	24-25
Food and Pharmaceutical	26-27

Stud Style (Inch) 30-55

Plain, Concentric	30-31
Plain, Eccentric	32-33
Flanged, Concentric	34-35
Flanged, Eccentric	36-37
V-Grooved, Concentric	38-39
V-Grooved, Eccentric	40-41
Flanged Crown, Concentric	42-43
Flanged Crown, Eccentric	42-43
Double-Flanged, Concentric	44-45
Stainless: Plain, Flanged, V-Grooved	46-49
High-Temp: Plain, Flanged, V-Grooved	50-51
Nylon: Concentric and Eccentric	52-53
Urethane: Concentric and Eccentric	54-55

Yoke Style and Shafts (Inch) 56-61

Plain	56
Crowned	57
Flanged	58
V-Grooved	59
Heavy-Duty Shafts, Concentric	60
Heavy-Duty Shafts, Eccentric	61

Stud Style (Metric) 62-73

Plain, Concentric	62-63
Plain, Eccentric	64-65
Flanged, Concentric	66-67
Flanged, Eccentric	68-69
V-Grooved, Concentric	70-71
V-Grooved, Eccentric	72-73

Yoke Style and Shafts (Metric) 74-77

Plain	74
Flanged	75
V-Grooved	76
Heavy-Duty Shafts, Concentric	77

Cam Runners® 78-79

Part Numbering Convention 82

Installation Procedures 83-85

Tightening Torque	83
Hex Socket Sizes	85

Quotation/Order Forms 86-87

Load Runners

Product Information

Choosing the right idler roller and rail solution for your application can make or break your bottom line.

Often the “unsung hero” in the application, idler rollers play a significant role in the overall success of any rail-riding operation. Properly specified, idler rollers optimize line speed and product handling, regardless of material run or machinery used.

If you’re involved with product selection, operating parameters, or sourcing, contact the Osborn team for support throughout the entire design/specification/sourcing process.

Application Considerations:

The proper selection and application of power transmission products and components, including the related area of product safety, is the responsibility of the customer. Operating and performance requirements and potential associated issues will vary appreciably depending on the use and application of such products or components.

The scope of the technical and application data included in this publication is necessarily limited. Unusual operating environments and conditions, lubrication requirements, loading supports, and other factors can materially affect the application and operating results of the products and components, and the customer should carefully review its requirements.

Any technical support, advice or review provided by Osborn and its divisions with respect to the use of products and components is given in good faith and without charge, and Osborn assumes no obligation or liability for the advice given, or results obtained, all such advice and review being given and accepted at customer's risk.

What is the application environment?

Environmental conditions can impact the life and performance of load bearing roller assemblies. Applications with exposure to one or more of the following operating environments may require special consideration:



Terms and Conditions:

For a copy of Osborn's standard terms and conditions of sale, disclaimers of warranty, limitations of liability and remedy, please contact Osborn customer care at 1-800-720-5248. These terms and conditions of sales, disclaimers, and limitations of liability and remedy, apply to any person who may buy, acquire, or use Osborn (Load Runners, Cam Runners or Load Rail) referred to herein, including any person who buys from a licensed distributor of Osborn products.

WHAT'S YOUR Challenge?

Load bearing roller assemblies are designed to support moving (dynamic) loads or stationary (static) loads. The load that the rollers will be supporting can be communicated using the following terminology:

Radial Load: Load applied to 90 degrees with the bearing bore or axis of rotation.

Thrust Load: Load applied parallel with the bearing bore or axis of rotation.

Rollers in many applications experience a load comprised of radial and thrust load which can be referred to as **combination load**. This load may not be intentionally designed into the application, but a combination load can be created as a result of misalignment or other functions within the application.

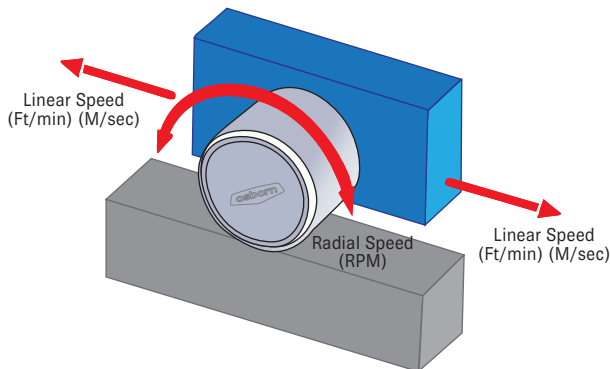
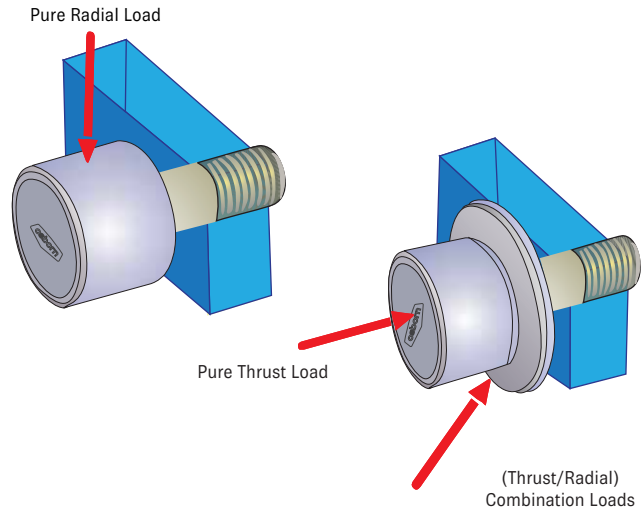

What are the applied speeds?

The rate at which the moving object will be traveling can be communicated in two different ways, in distance per time (FPM, M/sec) for linear movement or in revolutions per minute (RPM) for rotational movement. Depending on the type of application, one of these will best communicate the applied speed.

What are the needs for location?

Load bearing roller assemblies facilitate the location of moving loads or the contact surface by allowing for specific movements and by limiting unwanted ones. Applications must be reviewed to determine the required **freedom of motion** and desired **constraint of movement**.

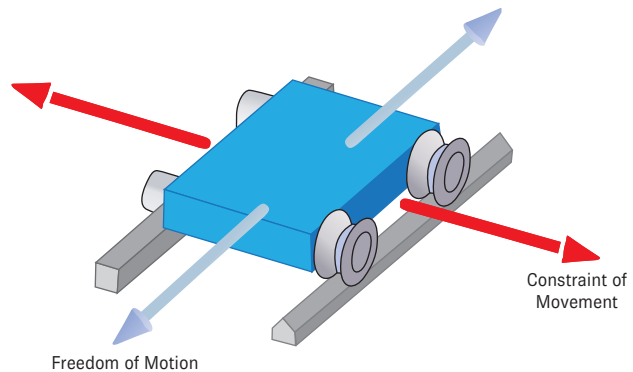

Load Runners

Overview & Technical Information

WE ARE Load Runners

Load Runners Load Guidance Systems for Precision Handling of Heavy Loads in Tough Environments

When reliability is paramount, combine the high capacity of Load Runners idler-rollers with long-lasting, rugged Load Rails®, to move your products, people, or process from Point A to Point B.

Designed To Endure Extreme Operating Conditions

Load Runners' treads are machined from high-alloy steel, then case hardened (Rc 55-60) for a wear-resistant outer shell and tough inner core.

Precision tapered roller bearings (larger sizes) and deep-groove ball bearings withstand heavy radial and thrust loads.

All Load Runners are tightly sealed and lubricated for life to withstand dirt, sand and moisture.

High-shear-strength studs feature a hex socket for easy installation, and thru-shafts eliminate the need for customer fabrication.

- Standard styles: plain, v-grooved, flanged, crowned, double-flanged, and flanged crown.
- Handle both radial and thrust loads
- Case hardened to Rc 55-60
- Lubricated and sealed for life
- Matching precision Load Rails hardened to Rc 60-65
- In-stock availability or short lead-time custom designs
- Backed by a professional, technical inside team



CUSTOM Engineered

In addition to the standard Load Runners idler-rollers listed in this catalog, custom tread profiles, studs and special features are available. A few examples include:

1. Crowned profiles
2. Solid lubricants
3. Double-flange rollers
4. Stainless steel treads, studs
5. Special plating (zinc, chrome etc.)
6. Non-metallic tread materials (urethane, nylon, etc.)
7. Special seals
8. Special lubricants
9. Provision for re-lubrication

Consult Osborn with special features or requirements not listed.

Operation in Severe Environments

Temperature Extremes

Standard Load Runners idler-rollers are designed to operate in temperatures ranging from -30° F to +225° F (-34° C to +107° C).

Operation in extreme temperature environments as low as -40°F (-40°C) and as high as +325°F (+162°C) requires special seals and/or lubrication provisions.

Moisture Extremes

Operation in wash-down or similar extreme-moisture environments may also require special lubrication provisions.

Consult Osborn for application assistance.

Bearing Disassembly (If Required)

Tapered-roller-bearing assemblies used in Load Runners idler-rollers are pre-set with custom-ground spacers for the correct running clearance. If a bearing assembly is removed and then reassembled, the same cups, cones and spacers must be used.

Bearing assembly components cannot be mixed and matched. Even new cups or cones cannot be substituted in an existing assembly.

Osborn does not recommend disassembly and does not provide separate component parts.

Application Considerations

The customer assumes responsibility for proper selection and application of Osborn Load Runners, Cam Runners and Load Rails. Technical advice or review provided by Osborn with respect to the use of Osborn products is given in good faith and without charge, and Osborn assumes no obligation of liability for the advice given. Advice provided is to be accepted at the customer's risk.



Load Runners

Heavy-Duty Idler Rollers & Rail

HIGHLY ENGINEERED Highly Regarded

Every Application Has Its Own Unique Requirements

Engineering expertise and manufacturing skills are what set the Load Runners brand apart. We collaborate with customers across the globe to solve their unique load-handling challenges all with one common goal: achieving optimum results. Before recommending a custom solution, we consider many specific attributes: moisture extremes, temperature, speed, loads, lubrication requirements, operating environment, and cycle counts.

In addition to thousands of standard products sold in more than 120 countries, Osborn offers local technical and customer support that's just a phone call/email away. No matter where you or your customers are located, you'll always have access to Osborn's application expertise and the industry's leading idler-roller/rail design and support team.

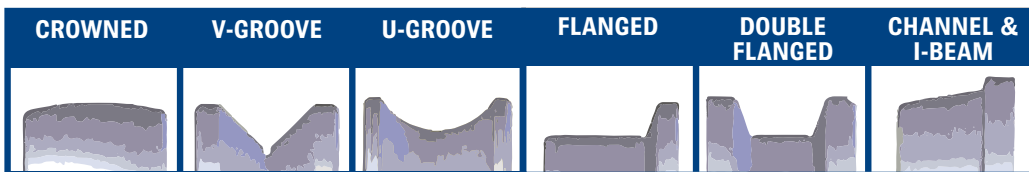

Superior Design Means Longer Life. Longer Life Means Lower Costs.

Osborn Load Runners are robust assemblies of carefully fabricated outer shells/treads and precision bearings fitted to high tolerance shafts. All Osborn Load Runners match the tread, shaft and bearings into a cohesive, highly engineered unit used in dozens of industries and hundreds of applications.

Manufactured in the USA, Load Runners feature heat-treated specialty steel, precision bearings, a maintenance-free lubrication and seal system, and a global network of sales support and application engineering expertise.

Osborn Load Runners are designed and manufactured using exacting engineering principles with an emphasis on achieving:

- Better balance
- Increased bearing life
- Less tread/outer shell wear
- Reduced power consumption
- Smooth performance
- Quieter operation

We Keep Things Moving

Osborn Load Runners are the ultimate heavy-duty load rail and idler roller solution in the industry, providing precision performance across numerous applications. Available in all standard configurations -- either metric or inch, stud- or yoke-style -- ranging in rolling sizes up to 12 inches, Load Runners help reduce your design time and lower overall material handling system costs.

Our design engineers provide custom solutions to handle any challenge.

Custom Designs & Special Features

In addition to standard Load Runners, we create custom products for unique applications:

- Crowned profiles
- Double-flange rollers
- Stainless steel types
- Special plating (zinc, chrome, etc.)
- Non-metallic tread materials
- Special seals
- Special lubricants
- Provision for re-lubrication

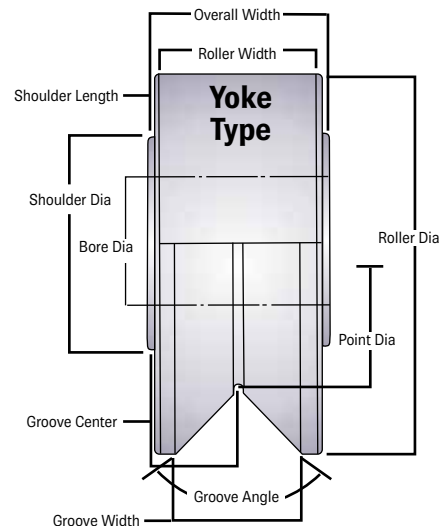
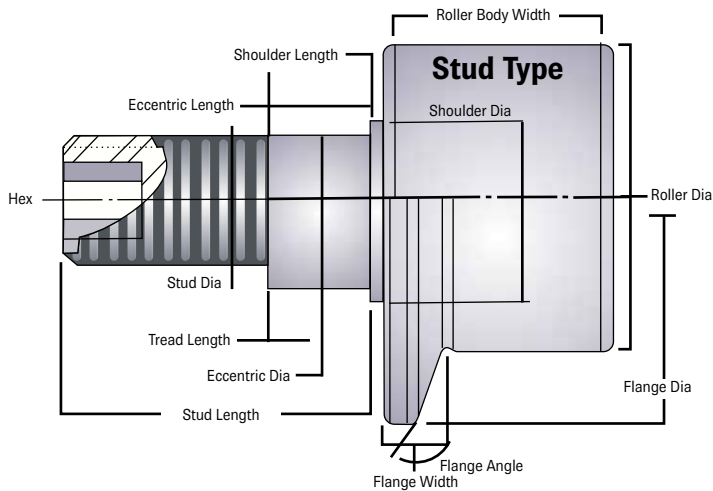

Unique Applications Require **UNIQUE SOLUTIONS**



Advanced Lubricant Improves Performance

Osborn's latest improvement to the Load Runner line is the addition of MicroPoly® solid lubricant to the bearing assemblies. MicroPoly is a mixture of polymers, oils, and additives that creates a solid lubricant with a porous oil-filled structure. This structure fills the airspace between bearings and race, keeping out the contaminants while retaining oil in the pores. Bearings are lubricated by capillary action. There is no need for maintenance or additional lubrication. Contact Osborn to determine whether MicroPoly can enhance your roller performance.

MicroPoly® is a registered trademark of PhyMet, Inc.

Rollers are manufactured to accommodate multiple mounting arrangements. The two most common mounting arrangements are stud-type and yoke-type:

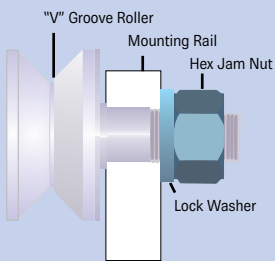

Through-Hole Mount Stud Type

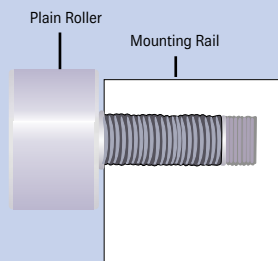

Blind Mount Stud Type

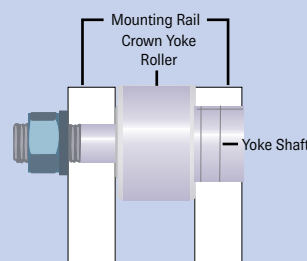

Captured Mount Yoke Type

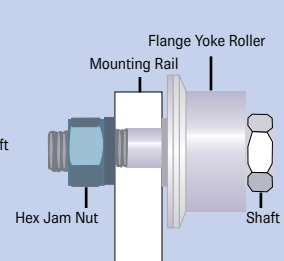

Through-Hole Mount Yoke Type

For applications requiring precision alignment between a roller and contact surface, an eccentric style roller may be used to achieve uniform contact.

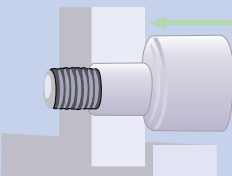

1. Mount

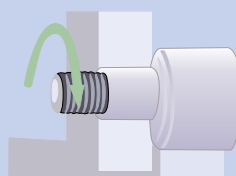

2. Adjust

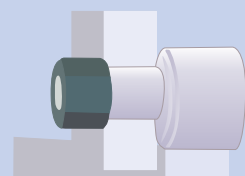

3. Fasten

Maximum DESIGN FLEXIBILITY



Osborn Load Rails® are made of high-strength steel and machined to tight tolerances, then cut to length and drilled to customer specifications. Osborn Load Rails are hardened on the rolling surface to 60-65 Rc. To determine a part number, specify the profile, replace "XXXX" with the track length dimension, and add the appropriate mounting option code (see chart). For example - to specify a 4" high V-track 28-1/2" long with a clearance hole for a cap screw, the part number is: LRTV-20284-1. Track length tolerance is $\pm 1/16"$. Osborn Load Rails offer allowable rail loadings up to 71,500 lbs (317450 N) per roller. Osborn Load Rails also available in metric, upon request.

Part No	Measurement in Inches								Mounting		
	Lgth	A	B	C	D	E	F	G	Option 1	Option 2	Option 3
LRTV-4 XXXX	72"	2.0	1.0	.125	.375	0.75	0.780	0.500	1/4 Cap Screw	1/4 Soc. Hd. Cap Screw	1/4-20 UNC Cap Screw
LRTV-1 XXXX	144"	3.0	1.5	.250	.500	1.00	1.047	0.750	3/8 Cap Screw	3/8 Soc. Hd. Cap Screw	3/8-16 UNC Cap Screw
LRTV-2 XXXX	144"	4.0	2.0	.250	.750	1.50	1.562	1.000	1/2 Cap Screw	1/2 Soc. Hd. Cap Screw	1/2-13 UNC Cap Screw
L RTP-4 XXXX	72"	2.0	1.0	.125	-	-	0.780	0.500	1/4 Cap Screw	1/4 Soc. Hd. Cap Screw	1/4-20 UNC Cap Screw
L RTP-1 XXXX	144"	3.0	1.5	.250	-	-	1.047	0.750	3/8 Cap Screw	3/8 Soc. Hd. Cap Screw	3/8-16 UNC Cap Screw
L RTP-2 XXXX	144"	4.0	2.0	.250	-	-	1.562	1.000	1/2 Cap Screw	1/2 Soc. Hd. Cap Screw	1/2-13 UNC Cap Screw
HPTV-4 XXXX	72"	1.0	1.0	-	-	-	1.030	-	-	-	1/4-20 UNC Cap Screw
HPTV-1 XXXX	144"	1.5	1.5	-	-	-	1.547	-	-	-	3/8-16 UNC Cap Screw
HPTV-2 XXXX	144"	2.0	2.0	-	-	-	2.062	-	-	-	1/2-13 UNC Cap Screw

XXX	X
Track length in whole inches	Fractional track length
001 = 1"	0 = 0
002 = 2"	1 = 1/8"
003 = 3"	2 = 1/4"
004 = 4"	3 = 3/8"
005 = 5"	4 = 1/2"
006 = 6"	5 = 5/8"
etc.	6 = 3/4"
	7 = 7/8"
Maximum Track Length = 144"	

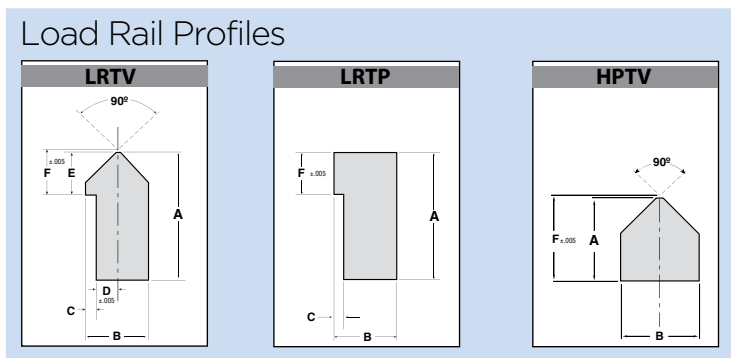
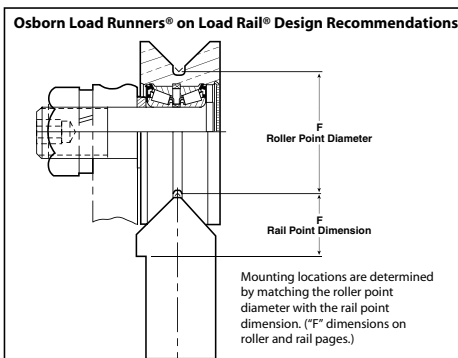
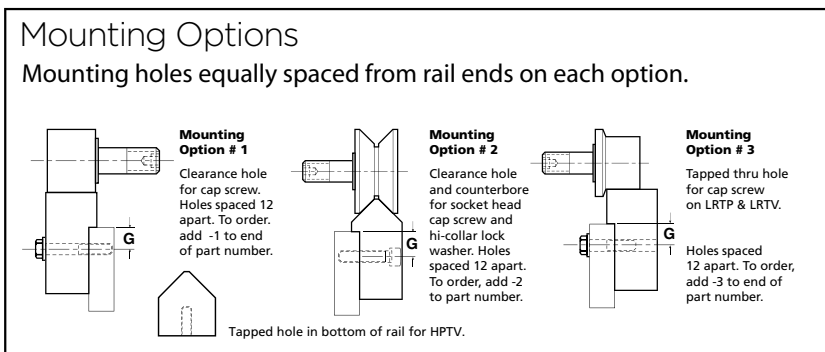

**Note: Other configurations and dimensions available.

CUSTOMER DESIGNED

Track Requirements

Track Alignment

Whether using our rail or yours, the track and roller should be aligned so that the roller tread lies flat on the track surface.

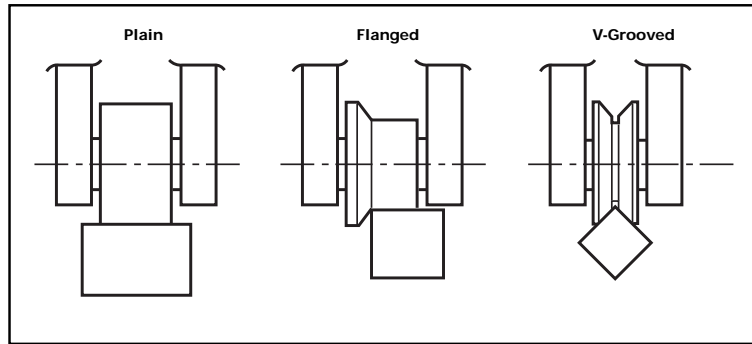

Track Capacity

For steel track of 180,000 PSI tensile strength (Rc=40), refer to the track capacity chart to find the track load capacity for the style and size of roller to be used. For steel track other than 180,000 PSI tensile strength, first refer to the track capacity factor chart for the type of steel to be used. Then multiply the track capacity for the roller being used by the track capacity factor for the steel to be used.

TRACK CAPACITY*						TRACK CAPACITY FACTOR			
PLR & PLRY		FLR & FLRY		VLR & VLRY		Track Hardness Rc	Tensile Strength		Capacity Factor
Roller Size	Capacity	Roller Size	Capacity	Roller Size	Capacity				
3	14,760 LBS.	3	10,500 LBS.	3 1/2	8,100 LBS.	26	120,000 PSI	0.369	
	65,680 N		44,720 N		36,000 N		8,437 Kg/Cm2		
3 1/4	16,000 LBS.	3 1/4	10,900 LBS.	4 1/2	13,200 LBS.	32	140,000 PSI	0.552	
	71,200 N		48,500 N		58,800 N		9,843 Kg/Cm2		
3 1/2	17,225 LBS.	3 1/2	14,200 LBS.	5	15,000 LBS.	36	160,000 PSI	0.755	
	76,650 N		63,190 N		66,600 N		11,249 Kg/Cm2		
4	25,300 LBS.	4	19,000 LBS.	5 1/2	16,700 LBS.	40	180,000 PSI	1.000	
	112,580 N		84,550 N		74,400 N		12,655 Kg/Cm2		
5	38,650 LBS.	5	29,400 LBS.	6 1/2	20,200 LBS.	44	200,000 PSI	1.235	
	172,000 N		130,830 N		90,100 N		14,061 Kg/Cm2		
6	54,830 LBS.	6	47,730 LBS.	7 1/2	23,800 LBS.	47	220,000 PSI	1.494	
	244,000 N		212,400 N		106,000 N		15,467 Kg/Cm2		
7	73,810 LBS.	7	60,860 LBS.	8 1/2	27,300 LBS.	50	240,000 PSI	1.777	
	328,450 N		270,830 N		121,000 N		16,874 Kg/Cm2		
8	95,600 LBS.	8	82,220 LBS.	9 1/2	30,800 LBS.	53	260,000 PSI	1.995	
	425,400 N		365,880 N		137,000 N		18,280 Kg/Cm2		
9	120,200 LBS.	9	105,160 LBS.	10 1/2	34,300 LBS.	56	280,000 PSI	2.209	
	534,900 N		467,960 N		153,000 N		19,686 Kg/Cm2		
10	147,600 LBS.	10	130,900 LBS.	11 1/2	37,900 LBS.	58	300,000 PSI	2.306	
	656,800 N		582,500 N		168,000 N		21,092 Kg/Cm2		

* Radial load only for tracks made of 180,000 PSI steel (Hardness Rc = 40)

INDUSTRY SPOTLIGHT

Primary Metals

TOUGH ENVIRONMENTS REQUIRE TOUGH PRODUCTS...

A steel mill was experiencing premature bearing failure that it suspected was a lubrication problem. After nearly two years of frequently replacing bearings, the company called Osborn.

Once on-site, the Osborn field sales engineer confirmed a lubrication problem, but also identified a more urgent problem...the customer was using undersized rollers. Compounding the problem, the application included significant shock loads that were damaging the bearings almost immediately upon installation. After solving the shock load issue, Osborn configured a completely new solution with beefier, case-hardened eccentric Load Runners and used proprietary high-temperature lubrication. Before the change, the old cam followers were lasting less than two months. The mill's new Load Runners have been in service more than six months and they're still going strong.



Other related applications

- Foundries
- Mold Handling Equipment
- Steel Mills
- Heat Treat Furnaces
- Recycling Scrap Yards
- Shredders
- Aluminum and Copper Plants



RELIABILITY THROUGH PROPER ALIGNMENT...

A customer in the oilfield in Alberta, Canada was experiencing an ongoing misalignment problem with their cam follower and rail system. After several failed attempts to re-align the rails on their own, they called Osborn.

The problem they faced is fairly common -- parallel rails with extended runs using plain cam followers and rail exclusively has a tendency to misalign. The solution was rather straight-forward: Osborn engineers specified v-groove cam followers and rail on one side, and plain cam followers and rail on the other. This new, dual configuration provided the additional "wiggle room" needed to help maintain system tolerances, and prevent premature failure. Best yet, as stock product, the replacement rails and Load Runners were delivered, installed, and performing flawlessly just two weeks after the order was placed.

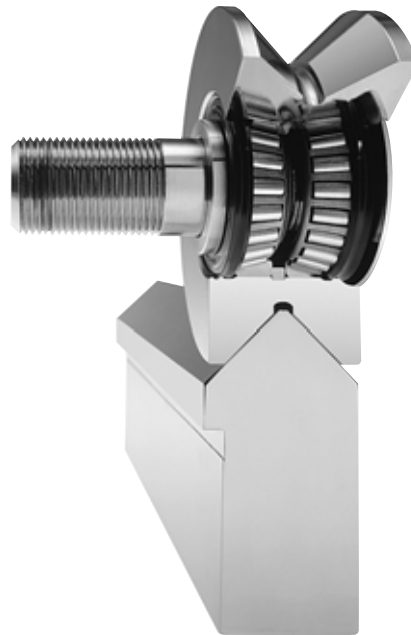

Other related applications

- Coiled Tubing
- Injection Systems
- Power Tongs
- Fracking



KEEPING ASSEMBLY ON TRACK...

Load Runners are used on conveyor and handling systems in assembly plants and cylinder-actuated carriages on equipment, such as paint operations, sub-assemblies, automated storage and retrieval systems. High levels of weld spray and dirt combined with fluctuating ambient temperatures can spell disaster for idler rollers. Not only are Load Runners up to the operating environment, but they are designed to handle both high loads and speeds. Best yet, all Load Runners are tightly sealed and lubricated for life.



Other related applications

- Assembly and Paint Line Conveying Systems
- Automated Storage and Retrieval
- Robotic Welders



INDUSTRY SPOTLIGHT

Off-Highway Equipment: Agriculture, Construction, and Mining

KEEP YOUR MACHINE RUNNING STRONG...

...with Osborn Load Runners and Load Rails.

Osborn Load Runners have proven themselves in machines from sugar cane harvesters to haulage trucks, all manufactured by such companies as Caterpillar, Case, Komatsu, International, Liebherr, John Deere, Dresser, etc.

Approximately 20 percent of any off-road heavy machinery's purchase price is contained in the undercarriage. More importantly, nearly 50 percent of maintenance costs will go into maintaining it. We know that one weak link in a system can cause a problem. That's why many undercarriage systems are integrally designed using Load Runners and Load Rails®. Osborn engineers work with your design team so that all components are carefully matched in a performance profile (tolerance, strength, hardness, and wear limits) for optimum performance and product life cycle. Although wear can never be eliminated, you can prolong the wear life of components and minimize maintenance costs with the properly designed idler roller and rail solution.

Other related industries

- Construction
- Mining
- Pulp and Paper
- Sawmills





STUCK BETWEEN A ROCK & A HARD PLACE...

A large aggregate supplier was having premature cam follower bearing failure at the end of its heavy-duty material handling line. Loose material was falling onto the rails and repeatedly jamming the treads, causing excess heat and breach of seal integrity.

Working with the local distributor, Osborn analyzed the application and changed out the quarry's rail and cam followers to a stock Load Runners V-groove configuration. The improvement over the previous solution was immediate and dramatic.

The resulting product performance was measured at more than five times that of the previous plain cam follower and rail combination. The company's investment in Load Runners translated into less downtime and increased productivity.



Other related applications

- Cement
- Concrete Batch Feeding Systems
- Hot Clinker Apron Conveyor
- Sand and Gravel
- Telescoping Conveyors and Stackers
- Screening Systems
- Coal
- Feeders, Hoppers, Bins and Gates



DESIGNED BY ENGINEERS FOR ENGINEERS...

Load Runners and Load Rails are proven performers in some of the world's most challenging applications. Through collaborative and visionary engineering on some of the world's large moveable structures, Load Runners have become the workhorse of the kinetic architecture world. Strong and sturdy, Osborn's heavy-duty, custom solutions have powered kinetic architectural projects across the globe with challenging load cases, including operable roofs from 80'–200' and operable walls as tall as 139'.

Featuring tapered roller bearings, Load Runners heavy-duty idler roller bearings handle both heavy radial as well as thrust loads. Maintenance-free units are lubed for life with seals to keep out sand, moisture, and other contaminants. Load Runners are manufactured in either inch or metric dimensions in virtually limitless geometries and tread configurations. Typical tread profiles are plain, flanged, or V-grooved.

Important Note For All Designers and Engineers:

To ensure any product selection performed provides the end users with the lowest total cost of ownership, we have provided a design submission sheet, located on page 86 of this catalog. This selection process may result in some dimensions of the selected product(s) differing from those stated in this catalog or on loadrunners.com.

In the interest of product development, Osborn reserves the right to change critical data at any time without prior notice. Dimensions shown are nominal only. Certified drawings are available upon request.

Other related applications

- Wall Units
- Set Design
- Retractable Doors / Ceilings
- Bridges, Gangways
- Satellite Dish / Telescope Positioning





PEAS & GREASE DON'T MIX...

From low-speed, quiet applications (for patient comfort) on medical equipment to high-speed pharmaceutical packaging applications, Osborn has the right product for the right application.

A Midwest-based food processor was struggling with lubricant contamination due to cam follower needle bearing failure in an overhead line.

After an extensive on-site assessment, the canning line in question was identified as a perfect candidate for Cam Runners™.

Cam Runners are dimensionally interchangeable with existing needle bearings with numerous, additional money- and time-saving features:

- Composite, synthetic treads are permanently assembled on a stainless steel stud, extending product life beyond traditional needle bearings
- No lubrication required to contaminate the food processing line
- No needle rollers means nothing skews, wears out or makes noise
- Cam Runners™ operate in a wide temperature range



Other related applications

- Bakery Cooling Towers
- Drug Packaging Conveyors
- Can Processing Equipment
- MRI Machines
- Bottle-Filling Machines



Product Listing and Information Load Runners and Cam Runners

Load Runners

Plain - Concentric Stud Style, Inch Sizes

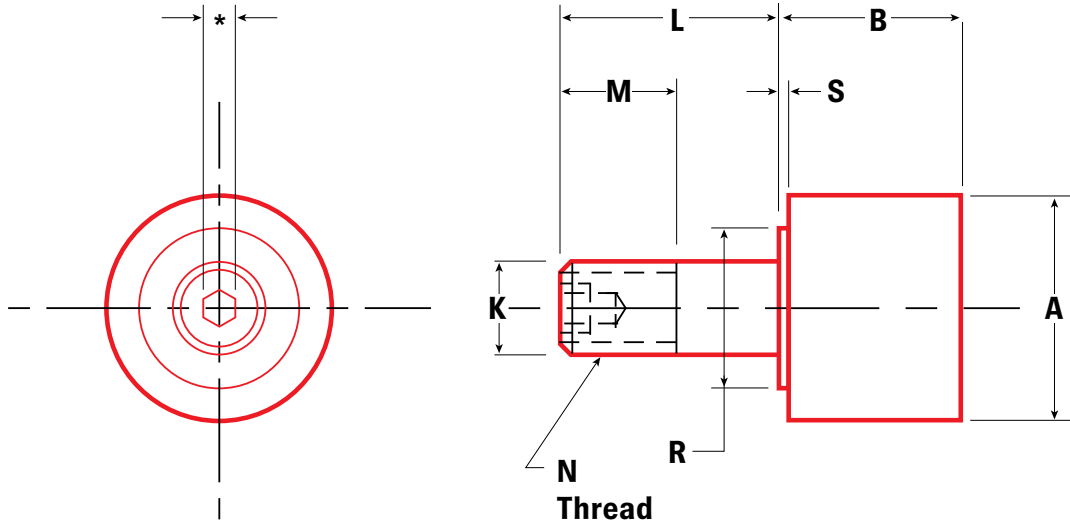

For metric sizes, please turn to page 62

Part No.	Item No.	A	B	K	L	M	N	R	S	Rec. Mtg. Hole Size	Mounting Member Thickness	
		Roller Dia	Roller Width	Stud Dia	Stud Length	Thread Length	Thread	Shoulder Diameter	Shoulder Length		Max	Min
		+0.000 -0.001		+0.000 -0.001							+0.001 -0.000	
PLR-1	97318	1.000	0.781	0.437	1.000	0.500	7/16-20	0.500	0.031	0.438	0.625	0.500
PLR-1-1/8	97319	1.125	0.781	0.437	1.000	0.500	7/16-20	0.500	0.031	0.438	0.625	0.500
PLR-1-1/4	97320	1.250	0.844	0.500	1.250	0.625	1/2-20	0.625	0.031	0.501	0.750	0.625
PLR-1-3/8	97321	1.375	0.844	0.500	1.250	0.625	1/2-20	0.625	0.031	0.501	0.750	0.625
PLR-1-1/2	95086	1.500	1.187	0.625	1.500	0.750	5/8-18	0.750	0.062	0.626	1.000	0.750
PLR-1-3/4	95112	1.750	1.187	0.750	1.750	0.875	3/4-16	1.000	0.062	0.751	1.125	0.875
PLR-1-3/4-5	95115	1.750	1.437	0.500	0.875	0.750	1/2-13NC	0.625	0.312	0.501	-	-
PLR-2	95125	2.000	1.687	0.875	2.000	1.125	7/8-14	1.000	0.062	0.876	1.250	0.875
PLR-2-3	95126	2.000	1.375	0.875	2.000	1.125	7/8-14	1.000	0.062	0.876	1.250	0.875
PLR-2-1/4	95152	2.250	1.687	0.875	2.000	1.125	7/8-14	1.000	0.062	0.876	1.250	0.875
PLR-2-1/2	95160	2.500	1.687	1.000	2.250	1.500	1-14	1.250	0.062	1.001	1.250	0.750
PLR-2-1/2-10	95164	2.500	1.812	1.000	2.250	1.500	1-14	1.250	0.187	1.001	1.250	0.750
PLR-2-1/2-16	95165	2.500	1.812	1.000	2.250	1.500	1-14	1.250	0.062	1.001	1.250	0.750
PLR-2-3/4	95190	2.750	1.687	1.000	2.250	1.500	1-14	1.250	0.062	1.001	1.250	0.750
PLR-3	95200	3.000	2.000	1.250	2.500	1.750	1-1/4-12	1.750	0.062	1.251	1.250	1.000
PLR-3-1/4	95245	3.250	2.000	1.250	2.500	1.750	1-1/4-12	1.750	0.062	1.251	1.250	1.000
PLR-3-1/2	95248	3.500	2.000	1.250	2.750	1.750	1-1/4-12	1.750	0.062	1.251	1.500	1.250
PLR-4	95268	4.000	2.000	1.250	2.750	1.750	1-1/4-12	1.750	0.062	1.251	1.500	1.250
PLR-4-1/2	95304	4.500	2.000	1.250	2.750	1.750	1-1/4-12	1.750	0.062	1.251	1.500	1.250
PLR-5	95323	5.000	3.000	2.000	4.500	2.500	2-12	3.250	0.062	2.001	2.750	2.000
PLR-6	95353	6.000	3.000	2.500	5.500	3.250	2-1/2-12	3.250	0.062	2.501	3.250	2.000
PLR-7	95374	7.000	3.000	2.500	5.500	3.250	2-1/2-12	3.250	0.062	2.501	3.250	2.000
PLR-8	95386	8.000	3.000	2.500	5.500	3.250	2-1/2-12	3.250	0.062	2.501	3.250	2.000
PLR-10	95398	10.000	3.000	2.500	5.500	3.250	2-1/2-12	3.250	0.062	2.501	3.250	2.000
PLR-10-1	95399	10.000	5.000	4.250	9.000	4.000	3-1/2-4NC	5.000	0.125	4.252	5.750	5.125

Other sizes available on request.

*For stud hex socket size, see page 85.

For special features and custom design considerations, see page 87.

**Lock washer and jam nut available at additional cost. For size, see N dimension.

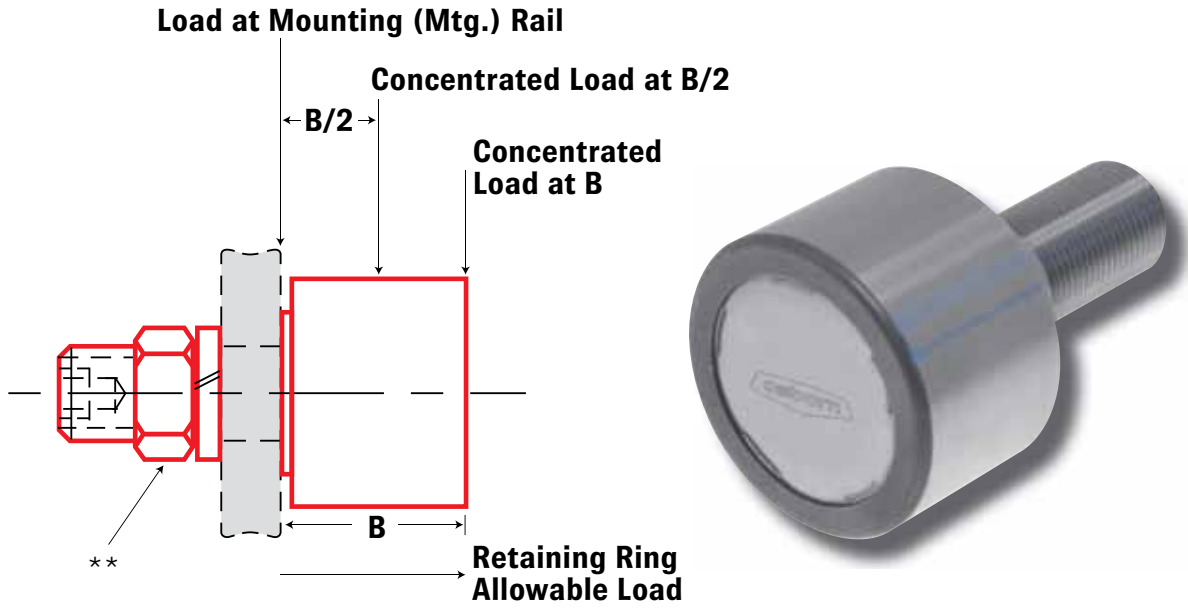

	Ball or Tapered Roller Bearings	Bearing Capacity Radial Load (lbs)			Bearing Capacity, Static Thrust (lbs)	Stud Capacity (lbs)			Retaining Ring Capacity (lbs)	Approx Weight (lbs)	Part No.
		3000 hrs L10 life @ 100 RPM	500 hrs L10 life @ 33 1/3 RPM	Static Limit		Bending=0.75 Sy		Shear=0.75 x 0.5 x Sy			
						Concent. Load @ B/2	Concent. Load @ B				
BB	240	630	230	140	480	210	1970	380	0.2	PLR-1	
BB	240	630	230	140	480	210	1970	380	0.3	PLR-1-1/8	
BB	520	1350	600	370	880	390	3250	470	0.3	PLR-1-1/4	
BB	520	1350	600	370	880	390	3250	470	0.4	PLR-1-3/8	
BB	1050	2760	1100	680	1390	650	5780	470	0.5	PLR-1-1/2	
BB	1050	2760	1100	680	1390	650	5780	470	0.8	PLR-1-3/4	
BB	1050	2760	1100	680	480	290	4150	470	0.7	PLR-1-3/4-5	
BB	1460	3830	1620	1000	4010	1500	11610	910	1.3	PLR-2	
BB	1460	3830	1620	1000	3090	1520	11610	910	1.2	PLR-2-3	
BB	1460	3830	1620	1000	4010	1500	11610	910	1.8	PLR-2-1/4	
BB	1980	5190	2270	1400	3730	1770	14580	1340	2.3	PLR-2-1/2	
BB	1980	5190	2270	1400	3730	1770	14580	1340	2.3	PLR-2-1/2-10	
TRB	4570	10880	7630	4570	6920	3700	25920	N/A	2.3	PLR-2-1/2-16	
BB	1980	5190	2270	1400	3730	1770	14580	1340	2.8	PLR-2-3/4	
TRB	6000	14270	20000	12000	12270	6330	40500	N/A	4.0	PLR-3	
TRB	6000	14270	20000	12000	12270	6330	40500	N/A	4.8	PLR-3-1/4	
TRB	6000	14270	20000	12000	12270	6330	40500	N/A	5.5	PLR-3-1/2	
TRB	6000	14270	20000	12000	12270	6330	40500	N/A	7.1	PLR-4	
TRB	6000	14270	20000	12000	12270	6330	40500	N/A	9.0	PLR-4-1/2	
TRB	13990	33290	51900	32500	34120	17350	103670	N/A	19.0	PLR-5	
TRB	15060	35840	56400	33100	66710	33910	161990	N/A	28.0	PLR-6	
TRB	15060	35840	56400	33100	66710	33910	161990	N/A	36.0	PLR-7	
TRB	15060	35840	56400	33100	66710	33910	161990	N/A	49.0	PLR-8	
TRB	15060	35840	56400	33100	66710	33760	161990	N/A	72.0	PLR-10	
TRB	34410	81890	159800	116000	194120	99480	468150	N/A	130.0	PLR-10-1	

LOAD CAPACITIES ARE BASED ON UNIFORM AND STEADY LOADING.

Load Runners

Plain - Eccentric Stud Style, Inch Sizes

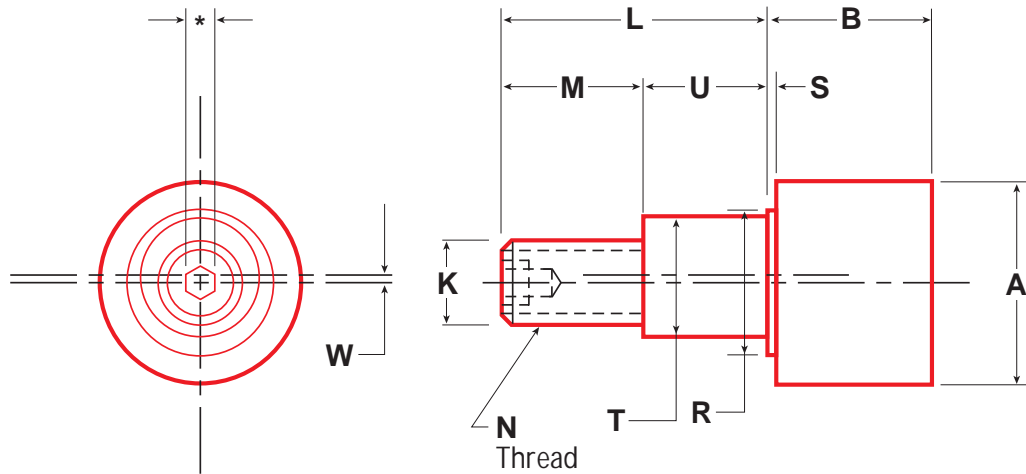

For metric sizes, please turn to page 64

Part No.	Item No.	A	B	K	L	M	N	R	S	T	U	W	Rec. Mtg. Hole Size
		Roller Dia	Roller Width	Stud Dia	Stud Length	Thread Length	Thread	Shoulder Dia	Shoulder Length	Eccentric Dia	Eccentric Length	Eccentricity	
		+0.000 -0.001								+0.001 -0.000	+0.000 -0.010		
PLRE-1	97322	1.000	0.781	0.437	1.000	0.500	7/16-20	0.750	0.031	0.625	0.500	0.030	0.627
PLRE-1-1/8	97323	1.125	0.781	0.437	1.000	0.500	7/16-20	0.750	0.031	0.625	0.500	0.030	0.627
PLRE-1-1/4	97324	1.250	0.844	0.500	1.250	0.625	1/2-20	0.812	0.031	0.687	0.625	0.030	0.689
PLRE-1-3/8	97325	1.375	0.844	0.500	1.250	0.625	1/2-20	0.812	0.031	0.687	0.625	0.030	0.689
PLRE-1-1/2	95849	1.500	1.188	0.625	1.500	0.770	5/8-18	1.125	0.062	0.875	0.730	0.030	0.877
PLRE-1-3/4	95853	1.750	1.188	0.750	1.750	0.895	3/4-16	1.240	0.062	1.000	0.855	0.030	1.002
PLRE-2	95857	2.000	1.688	0.875	2.000	1.020	7/8-14	1.500	0.062	1.187	0.980	0.030	1.189
PLRE-2-1/4	95863	2.250	1.688	0.875	2.000	1.020	7/8-14	1.500	0.062	1.187	0.980	0.030	1.189
PLRE-2-1/2	95869	2.500	1.688	1.000	2.250	1.145	1-14	1.687	0.062	1.375	1.105	0.030	1.377
PLRE-2-1/2-7	97603	2.500	1.812	1.000	2.250	1.145	1-14	1.687	0.062	1.375	1.105	0.030	1.377
PLRE-2-3/4	95875	2.750	1.688	1.000	2.250	1.145	1-14	1.687	0.062	1.375	1.105	0.030	1.377
PLRE-3	95876	3.000	2.000	1.250	2.500	1.270	1-1/4-12	2.312	0.062	1.750	1.230	0.060	1.752
PLRE-3-1/4	95887	3.250	2.000	1.250	2.500	1.270	1-1/4-12	2.312	0.062	1.750	1.230	0.060	1.752
PLRE-3-1/2	95888	3.500	2.000	1.250	2.750	1.395	1-1/4-12	2.312	0.062	1.812	1.355	0.060	1.814
PLRE-4	95892	4.000	2.000	1.250	2.750	1.395	1-1/4-12	2.312	0.062	1.812	1.355	0.060	1.814
PLRE-5	95900	5.000	3.000	2.000	4.500	2.375	2-12	3.250	0.062	2.625	2.125	0.060	2.627
PLRE-6	95903	6.000	3.000	2.500	5.500	2.625	2-1/2-12	3.625	0.062	3.125	2.875	0.060	3.127

Other sizes available on request.

**Flat washer, lock washer and jam nut available at additional cost. For size, see "N" dimension.

*For stud hex socket size, see page 85.

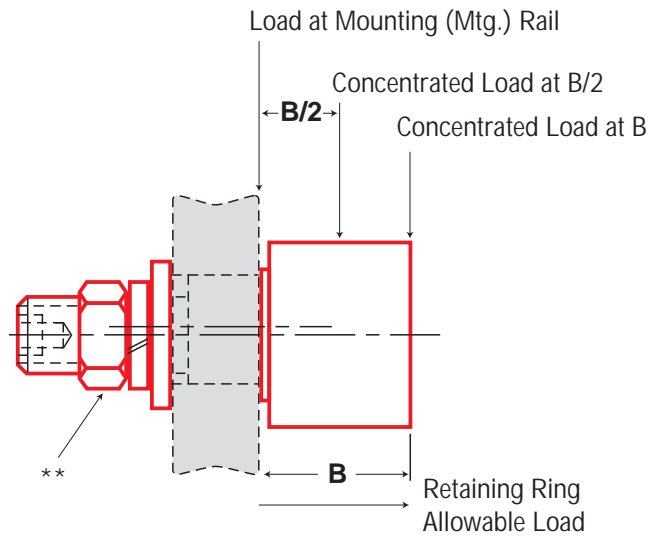

	Mounting Member Thickness		Ball or Tapered Roller Bearings	Bearing Capacity Radial Load (lbs)			Bearing Capacity, Static Thrust (lbs)	Stud Capacity (lbs)			Retaining Ring Capacity (lbs)	Approx Weight (lbs)	Part No.
	Max	Min		3000 hrs L10 life @ 100 RPM	500 hrs L10 life @ 33 1/3 RPM	Static Limit		Bending=0.75 Sy		Shear=0.75 x 0.5 x Sy			
								Concent. Load @B/2	Concent. Load @B				
	0.625	0.500	BB	240	630	230	140	480	210	1970	470	0.3	PLRE-1
	0.625	0.500	BB	240	630	230	140	480	210	1970	470	0.3	PLRE-1-1/8
	0.750	0.625	BB	520	1350	600	370	880	390	3250	470	0.4	PLRE-1-1/4
	0.750	0.625	BB	520	1350	600	370	880	390	3250	470	0.4	PLRE-1-3/8
	0.875	0.750	BB	1050	2760	1100	680	1390	650	5780	470	0.6	PLRE-1-1/2
	1.000	0.875	BB	1050	2760	1100	680	1390	650	5780	470	0.9	PLRE-1-3/4
	1.125	1.000	BB	1460	3830	1620	1000	4010	1500	11610	910	1.6	PLRE-2
	1.125	1.000	BB	1460	3830	1620	1000	4010	1500	11610	910	2.0	PLRE-2-1/4
	1.250	1.125	BB	1980	5190	2270	1400	3730	1770	14580	1340	2.5	PLRE-2-1/2
	1.250	1.125	TRB	4570	10880	7630	4570	6720	3640	14580	N/A	2.5	PLRE-2-1/2-7
	1.250	1.125	BB	1980	5190	2270	1400	3730	1770	14580	1340	3.4	PLRE-2-3/4
	1.375	1.250	TRB	6000	14270	20000	12000	12430	6370	40500	N/A	4.5	PLRE-3
	1.375	1.250	TRB	6000	14270	20000	12000	12430	6370	40500	N/A	5.4	PLRE-3-1/4
	1.500	1.375	TRB	6000	14270	20000	12000	12430	6370	40500	N/A	6.5	PLRE-3-1/2
	1.500	1.375	TRB	6000	14270	20000	12000	12430	6370	40500	N/A	8.3	PLRE-4
	2.500	2.250	TRB	13990	33290	51900	32500	34120	17350	103670	N/A	21.0	PLRE-5
	3.250	3.000	TRB	15060	35840	56400	33100	68710	33910	161990	N/A	30.5	PLRE-6

LOAD CAPACITIES ARE BASED ON UNIFORM AND STEADY LOADING.

Load Runners

Flanged - Concentric Stud Style, Inch Sizes

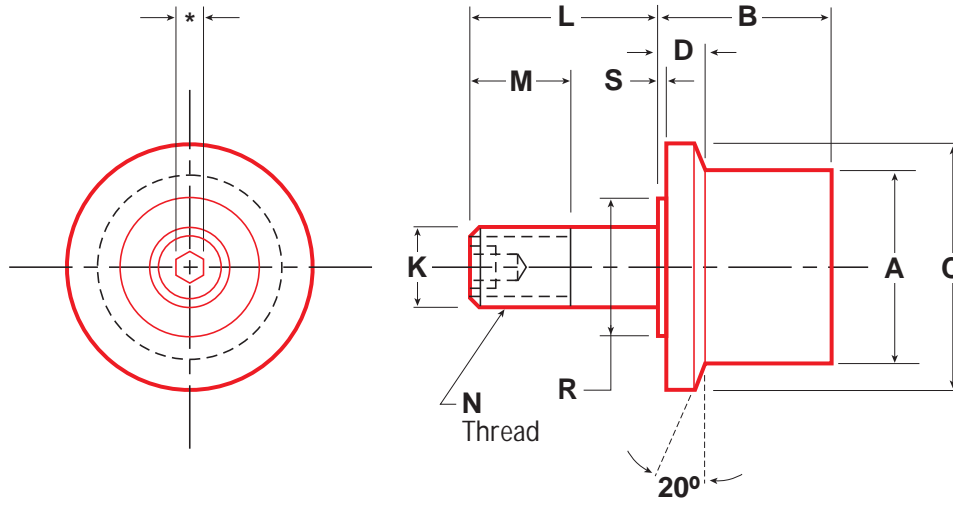

For metric sizes, please turn to page 66

Part No.	Item No.	A	B	C	D	K	L	M	N	R	S	Rec. Mtg. Hole Size
		Roller Dia	Roller Width	Flange Dia	Flange Thickness	Stud Dia	Stud Length	Thread Length	Thread	Shoulder Dia	Shoulder Length	
FLR-1	97326	1.000	0.781	1.375	0.219	0.437	1.000	0.500	7/16-20	0.500	0.031	0.438
FLR-1-1/8	97327	1.125	0.781	1.500	0.219	0.437	1.000	0.500	7/16-20	0.500	0.031	0.438
FLR-1-1/4	97328	1.250	0.844	1.563	0.219	0.500	1.250	0.625	1/2-20	0.625	0.031	0.501
FLR-1-3/8	97329	1.375	0.844	1.688	0.219	0.500	1.250	0.625	1/2-20	0.625	0.031	0.501
FLR-1-1/2	95445	1.500	1.188	2.188	0.343	0.625	1.500	0.750	5/8-18	0.750	0.062	0.626
FLR-1-1/2-2	95446	1.500	1.063	2.000	0.343	0.500	1.375	0.750	1/2-20	0.625	0.125	0.501
FLR-1-3/4	95472	1.750	1.188	2.438	0.343	0.750	1.750	0.875	3/4-16	1.000	0.062	0.751
FLR-2	95482	2.000	1.688	2.688	0.593	0.875	2.000	1.125	7/8-14	1.000	0.062	0.876
FLR-2-1/4	95498	2.250	1.688	2.938	0.593	0.875	2.000	1.125	7/8-14	1.000	0.062	0.876
FLR-2-1/2	95502	2.500	1.688	3.188	0.593	1.000	2.250	1.500	1-14	1.250	0.062	1.001
FLR-2-1/2-1	95503	2.500	1.812	3.188	0.593	1.000	2.250	1.500	1-14	1.250	0.062	1.001
FLR-2-3/4	95515	2.750	1.688	3.438	0.593	1.000	2.250	1.500	1-14	1.250	0.062	1.001
FLR-3	95520	3.000	2.000	3.938	0.593	1.250	2.500	1.750	1-1/4-12	1.750	0.062	1.251
FLR-3-1/4	95555	3.250	2.000	4.188	0.593	1.250	2.500	1.750	1-1/4-12	1.750	0.062	1.251
FLR-3-1/2	95558	3.500	2.000	4.438	0.593	1.250	2.750	1.750	1-1/4-12	1.750	0.062	1.251
FLR-4	95562	4.000	2.000	4.938	0.593	1.250	2.750	1.750	1-1/4-12	1.750	0.062	1.251
FLR-4M	95567	4.000	2.000	4.938	1.000	1.250	2.750	1.750	1-1/4-12	1.750	0.062	1.251
FLR-4-1/2	95591	4.500	2.000	5.438	0.593	1.250	2.750	1.750	1-1/4-12	1.750	0.062	1.251
FLR-5	95601	5.000	3.000	5.938	0.718	2.000	4.500	2.500	2-12	3.250	0.062	2.001
FLR-6	95625	6.000	3.000	6.938	0.718	2.500	5.500	3.250	2-1/2-12	3.250	0.062	2.501
FLR-7	95640	7.000	3.000	7.938	0.718	2.500	5.500	3.250	2-1/2-12	3.250	0.062	2.501
FLR-8	95641	8.000	3.000	8.938	0.718	2.500	5.500	3.250	2-1/2-12	3.250	0.062	2.501

Other sizes available on request.

**Flat washer, lock washer and jam nut available at additional cost. For size, see "N" dimension.

*For stud hex socket size, see page 85.

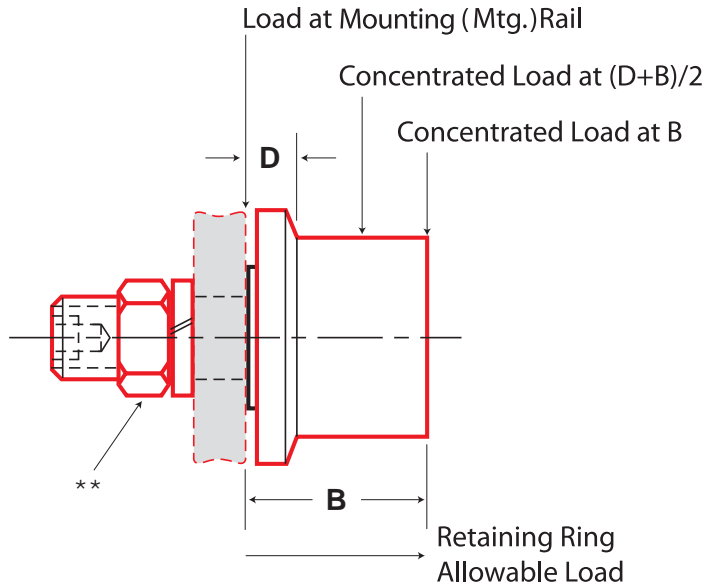

	Mounting Member Thickness		Ball or Tapered Roller Bearings	Bearing Capacity Radial Load (lbs)			Bearing Capacity, Static Thrust (lbs)	Stud Capacity (lbs)			Retaining Ring Capacity (lbs)	Approx Weight (lbs)	Part No.
	Max	Min		3000 hrs L10 life @ 100 RPM	500 hrs L10 life @ 33 1/3 RPM	Static Limit		Bending=0.75 Sy		Shear=0.75 x 0.5 x Sy			
								Concent. Load @ (D+B)/2	Concent. Load @ B				
	0.625	0.500	BB	240	630	230	140	370	210	1970	380	0.3	FLR-1
	0.625	0.500	BB	240	630	230	140	370	210	1970	380	0.3	FLR-1-1/8
	0.750	0.625	BB	520	1350	600	370	710	390	3250	470	0.4	FLR-1-1/4
	0.750	0.625	BB	520	1350	600	370	710	390	3250	470	0.4	FLR-1-3/8
	1.000	0.750	BB	1050	2760	1100	680	1100	650	5780	470	0.6	FLR-1-1/2
	1.000	0.750	BB	930	2430	970	600	700	420	4020	470	0.5	FLR-1-1/2-2
	1.125	0.875	BB	1050	2760	1100	680	1100	650	5780	470	1.0	FLR-1-3/4
	1.250	0.875	BB	1460	3830	1620	1000	2640	1500	11610	910	1.8	FLR-2
	1.250	0.875	BB	1460	3830	1620	1000	2640	1500	11610	910	2.1	FLR-2-1/4
	1.250	0.750	BB	1980	5190	2270	1400	2780	1770	14580	1340	2.8	FLR-2-1/2
	1.250	0.750	TRB	4570	10890	7630	4570	5460	3580	25920	N/A	2.8	FLR-2-1/2-1
	1.250	0.750	BB	1980	5190	2270	1400	2780	1770	14580	1340	3.2	FLR-2-3/4
	1.250	1.000	TRB	6000	14270	20000	12000	9880	6330	40500	N/A	4.7	FLR-3
	1.250	1.000	TRB	6000	14270	20000	12000	9880	6330	40500	N/A	5.3	FLR-3-1/4
	1.250	1.000	TRB	6000	14270	20000	12000	9880	6330	40500	N/A	6.2	FLR-3-1/2
	1.250	1.000	TRB	6000	14270	20000	12000	9880	6330	40500	N/A	7.9	FLR-4
	1.250	1.000	TRB	6000	14270	20000	12000	8530	6330	40500	N/A	8.1	FLR-4M
	1.250	1.000	TRB	6000	14270	20000	12000	9880	6330	40500	N/A	9.9	FLR-4-1/2
	2.750	2.000	TRB	13990	33290	51900	32500	28300	17350	103670	N/A	18.5	FLR-5
	3.250	2.000	TRB	15060	35840	56400	33100	55320	33910	161990	N/A	29.5	FLR-6
	3.250	2.000	TRB	15060	35840	56400	33100	55320	33910	161990	N/A	38.0	FLR-7
	3.250	2.000	TRB	15060	35840	56400	33100	55320	33910	161990	N/A	46.0	FLR-8

LOAD CAPACITIES ARE BASED ON UNIFORM AND STEADY LOADING.

Load Runners

Flanged - Eccentric Stud Style, Inch Sizes

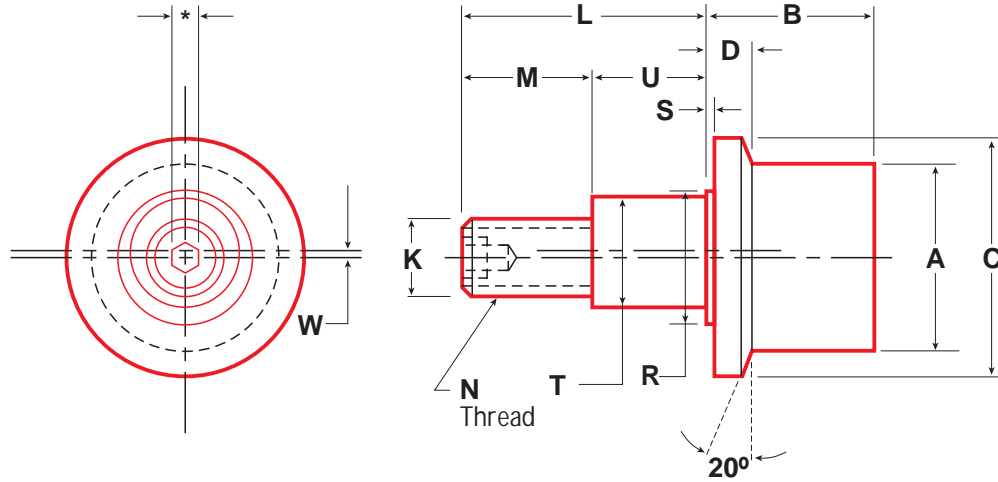

For metric sizes, please turn to page 68

Part No.	Item No.	A	B	C	D	K	L	M	N	R	S	T	U	W
		Roller Dia	Roller Width	Flange Dia	Flange Thickness	Stud Dia	Stud Length	Thread Length	Thread	Shoulder Dia	Shoulder Length	Eccentric Dia	Eccentric Length	
FLRE-1	97330	1.000	0.781	1.375	0.219	0.437	1.000	0.500	7/16-20	0.750	0.031	0.625	0.500	0.030
FLRE-1-1/8	97331	1.125	0.781	1.500	0.219	0.437	1.000	0.500	7/16-20	0.750	0.031	0.625	0.500	0.030
FLRE-1-1/4	97332	1.250	0.844	1.563	0.219	0.500	1.250	0.625	1/2-20	0.812	0.031	0.687	0.625	0.030
FLRE-1-3/8	97333	1.375	0.844	1.688	0.219	0.500	1.250	0.625	1/2-20	0.812	0.031	0.687	0.625	0.030
FLRE-1-1/2	95917	1.500	1.187	2.188	0.343	0.625	1.500	0.770	5/8-18	1.125	0.062	0.875	0.730	0.030
FLRE-1-3/4	95922	1.750	1.187	2.438	0.343	0.750	1.750	0.895	3/4-16	1.240	0.062	1.000	0.855	0.030
FLRE-2	95924	2.000	1.688	2.688	0.593	0.875	2.000	1.020	7/8-14	1.500	0.062	1.187	0.980	0.030
FLRE-2-1/4	95927	2.250	1.688	2.938	0.593	0.875	2.000	1.020	7/8-14	1.500	0.062	1.187	0.980	0.030
FLRE-2-1/2	95928	2.500	1.688	3.188	0.593	1.000	2.250	1.145	1-14	1.687	0.062	1.375	1.105	0.030
FLRE-2-1/2-4	97604	2.500	1.812	3.188	0.593	1.000	2.250	1.145	1-14	1.687	0.062	1.375	1.105	0.030
FLRE-2-3/4	95931	2.750	1.688	3.438	0.593	1.000	2.250	1.145	1-14	1.687	0.062	1.375	1.105	0.030
FLRE-3	95932	3.000	2.000	3.938	0.593	1.250	2.500	1.270	1 1/4-12	2.312	0.062	1.750	1.230	0.060
FLRE-3-1/4	95939	3.250	2.000	4.188	0.593	1.250	2.500	1.270	1 1/4-12	2.312	0.062	1.750	1.230	0.060
FLRE-3-1/2	95940	3.500	2.000	4.438	0.593	1.250	2.750	1.395	1 1/4-12	2.312	0.062	1.812	1.355	0.060
FLRE-4	95941	4.000	2.000	4.938	0.593	1.250	2.750	1.395	1 1/4-12	2.312	0.062	1.812	1.355	0.060
FLRE-4-1/2	95946	4.500	2.000	5.438	0.593	1.250	2.750	1.395	1 1/4-12	2.312	0.062	1.812	1.355	0.060
FLRE-5	95948	5.000	3.000	5.938	0.718	2.000	4.500	2.375	2-12	3.250	0.062	2.625	2.125	0.060
FLRE-6	95949	6.000	3.000	6.938	0.718	2.500	5.500	2.625	2 1/2-12	3.625	0.062	3.125	2.875	0.060

Other sizes available on request.

**Flat washer, lock washer and jam nut available at additional cost. For size, see "N" dimension.

*For stud hex socket size, see page 85.

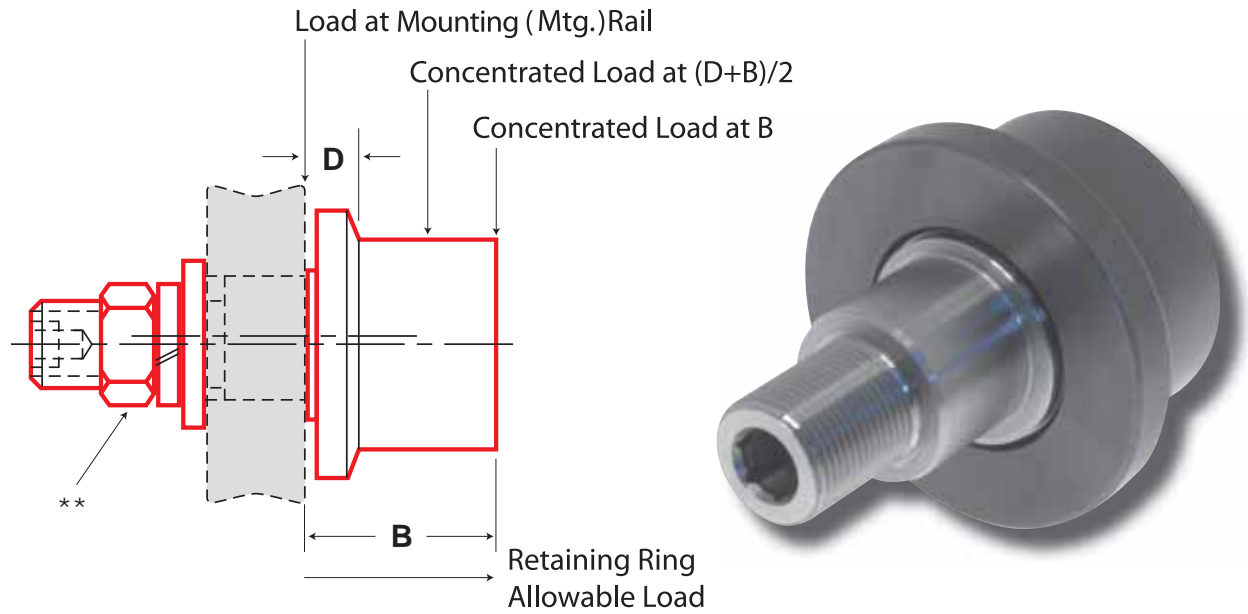

	Rec. Mtg. Hole Size	Mounting Member Thickness		Ball or Tapered Roller Bearings	Bearing Capacity Radial Load (lbs)			Bearing Capacity, Static Thrust (lbs)	Stud Capacity (lbs)		Retaining Ring Capacity (lbs)	Approx Weight (lbs)	Part No.	
		Max	Min		3000 hrs L10 life @ 100 RPM	500 hrs L10 life @ 33-1/3 RPM	Static Limit		Bending=0.75 Sy					Shear=0.75 x 0.5 x Sy
									Concent. Load @ (D+B)/2	Concent. Load @ B				
	0.627	0.625	0.500	BB	240	630	230	140	350	200	1970	380	0.3	FLRE-1
	0.627	0.625	0.500	BB	240	630	230	140	360	210	1970	380	0.4	FLRE-1-1/8
	0.689	0.750	0.625	BB	520	1350	600	370	710	390	3250	470	0.4	FLRE-1-1/4
	0.689	0.750	0.625	BB	520	1350	600	370	710	390	3250	470	0.5	FLRE-1-3/8
	0.877	0.875	0.750	BB	1050	2760	1100	680	1100	650	5780	470	0.8	FLRE-1-1/2
	1.002	1.000	0.875	BB	1050	2760	1100	680	1130	650	5780	470	1.1	FLRE-1-3/4
	1.189	1.125	1.000	BB	1460	3830	1620	1000	2640	1500	11610	910	2.1	FLRE-2
	1.189	1.125	1.000	BB	1460	3830	1620	1000	2640	1500	11610	910	2.5	FLRE-2-1/4
	1.377	1.250	1.125	BB	1980	5190	2270	1400	2780	1770	14580	1340	3.0	FLRE-2-1/2
	1.377	1.250	1.125	TRB	4570	10880	7630	4570	5340	3650	29920	N/A	3.0	FLRE-2-1/2-4
	1.377	1.250	1.125	BB	1980	5190	2270	1400	2780	1770	14580	1340	3.5	FLRE-2-3/4
	1.752	1.375	1.250	TRB	6000	14270	20000	12000	9980	6370	40500	N/A	5.1	FLRE-3
	1.752	1.375	1.250	TRB	6000	14270	20000	12000	9980	6370	40500	N/A	5.8	FLRE-3-1/4
	1.814	1.500	1.375	TRB	6000	14270	20000	12000	9980	6370	40500	N/A	6.8	FLRE-3-1/2
	1.814	1.500	1.375	TRB	6000	14270	20000	12000	9980	6370	40500	N/A	8.5	FLRE-4
	1.814	1.500	1.375	TRB	6000	14270	20000	12000	9980	6370	40500	N/A	10.5	FLRE-4-1/2
	2.627	2.500	2.250	TRB	13990	33290	51900	32500	28300	17350	103670	N/A	19.5	FLRE-5
	3.127	3.250	3.000	TRB	15060	35840	56400	33100	55320	33910	161990	N/A	32.0	FLRE-6

LOAD CAPACITIES ARE BASED ON UNIFORM AND STEADY LOADING.

Load Runners

V-Grooved - Concentric Stud Style, Inch Sizes

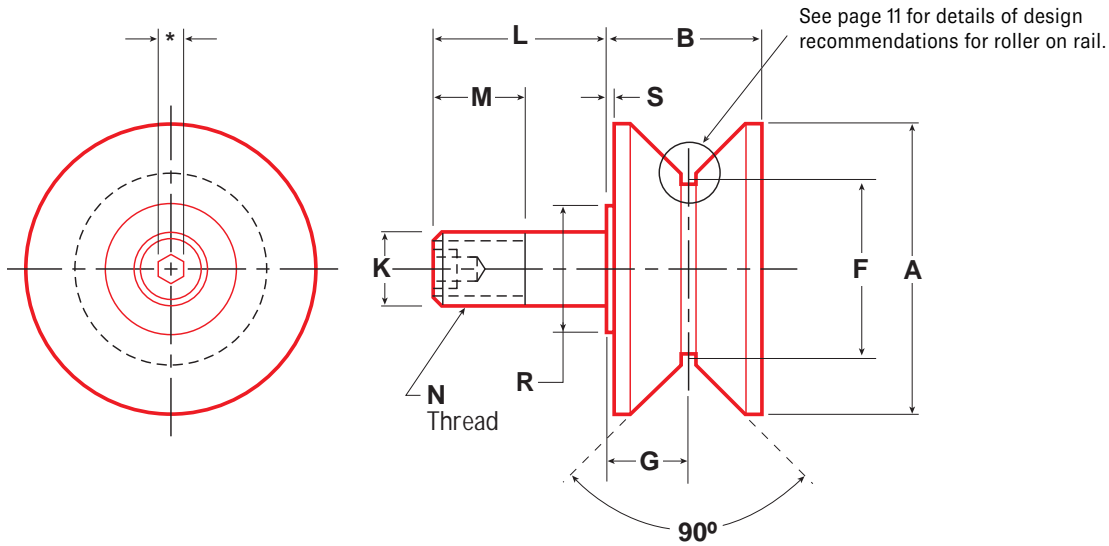

For metric sizes, please turn to page 70

Part No.	Item No.	A	B	F	G	K	L	M	N	R	S
		Roller Dia	Roller Width	Point Dia	Groove Location	Stud Dia	Stud Length	Thread Length	Thread	Shoulder Dia	Shoulder Length
VLR-1-1/2	97334	1.500	0.781	1.125	0.391	0.437	1.000	0.500	7/16-20	0.500	0.031
VLR-2	97335	2.000	0.844	1.375	0.422	0.500	1.250	0.625	1/2-20	0.625	0.031
VLR-2-1/2	95660	2.500	1.312	1.500	0.687	0.750	1.750	0.875	3/4-16	1.000	0.062
VLR-3-1/2	95678	3.500	1.687	2.250	0.875	0.875	2.000	1.125	7/8-14	1.000	0.062
VLR-3-1/2-16	95685	3.500	2.000	2.250	0.875	0.750	2.000	1.125	3/4-16	1.250	0.062
VLR-4-1/2	95729	4.500	2.000	3.000	1.000	1.250	2.500	1.750	1 1/4-12	1.750	0.062
VLR-5-1/2	95760	5.500	2.000	4.000	1.000	1.250	2.750	1.750	1 1/4-12	1.750	0.062
VLR-6-1/2	95770	6.500	3.000	5.000	1.500	2.000	4.500	2.500	2-12	3.250	0.062
VLR-7-1/2	95777	7.500	3.000	6.000	1.500	2.500	5.500	3.250	2-1/2-12	3.250	0.062
VLR-8-1/2	95782	8.500	3.000	7.000	1.500	2.500	5.500	3.250	2-1/2-12	3.250	0.062

Other sizes available on request.

**Lock washer and jam nut available at additional cost. For size, see "N" dimension.

*For stud hex socket size, see page 85.

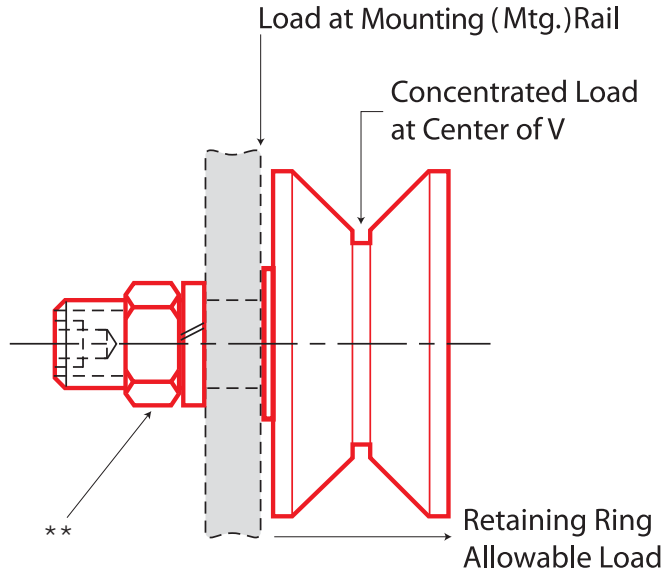

Rec. Mtg. Hole Size	Mounting Member Thickness		Ball or Tapered Roller Bearings	Bearing Capacity Radial Load (lbs)			Bearing Capacity, Static Thrust (lbs)	Stud Capacity (lbs)		Retaining Ring Capacity (lbs)	Approx Weight (lbs)	Part No.
	+0.001 -0.000	Max		Min	3000 hrs L10 life @ 100 RPM	500 hrs L10 life @ 33-1/3 RPM		Static Limit	Bending = 0.75 Sy Bend @V			
0.438	0.625	0.500	BB	240	630	230	140	370	1970	380	0.5	VLR-1-1/2
0.500	0.750	0.625	BB	520	1350	600	370	920	3250	470	0.6	VLR-2
0.751	1.250	1.000	BB	1050	2760	1100	680	1230	5780	470	1.3	VLR-2-1/2
0.876	1.250	1.000	BB	1980	5190	2270	1400	3730	14580	1340	3.4	VLR-3-1/2
0.751	1.250	1.000	TRB	3780	14270	7200	3150	3120	14580	N/A	3.4	VLR-3 1/2-16
1.251	1.250	1.000	TRB	6000	14270	20000	12000	12660	40500	N/A	7.0	VLR-4-1/2
1.251	1.500	1.250	TRB	6000	14270	20000	12000	12660	40500	N/A	10.5	VLR-5-1/2
2.001	3.000	2.000	TRB	15060	35840	^46030	^23010	34880	103670	N/A	25.5	VLR-6-1/2
2.501	3.250	2.250	TRB	15060	35840	^53860	^26930	68130	161990	N/A	37.0	VLR-7-1/2
2.501	3.250	2.250	TRB	15060	35840	56400	^30850	68130	161990	N/A	46.0	VLR-8-1/2

^Surface strength of roller OD

LOAD CAPACITIES ARE BASED ON UNIFORM AND STEADY LOADING.

Load Runners

V-Grooved - Eccentric Stud Style, Inch Sizes

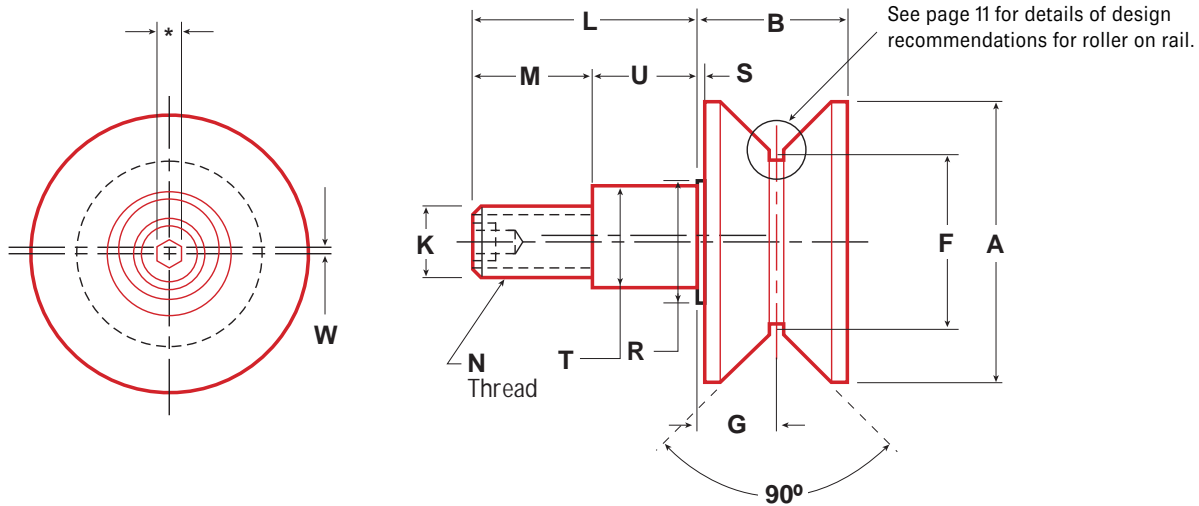

For metric sizes, please turn to page 72

Part No.	Item No.	A	B	F	G	K	L	M	N	R	S	T	U	W
		Roller Dia	Roller Width	Point Dia	Groove Location	Stud Dia	Stud Length	Thread Length	Thread	Shoulder Dia	Shoulder Length	Eccentric Dia	Eccentric Length	
VLRE-1-1/2	97336	1.500	0.781	1.125	0.391	0.437	1.000	0.500	7/16-20	0.750	0.031	0.625	0.500	0.030
VLRE-2	97337	2.000	0.844	1.375	0.422	0.500	1.250	0.625	1/2-20	0.812	0.031	0.687	0.625	0.030
VLRE-2-1/2	95958	2.500	1.312	1.500	0.687	0.750	1.750	0.895	3/4-16	1.375	0.062	1.000	0.855	0.030
VLRE-3-1/2	95970	3.500	1.687	2.250	0.875	0.875	2.000	1.020	7/8-14	1.500	0.062	1.187	0.980	0.030
VLRE-3-1/2-4	95973	3.500	1.890	2.250	0.875	0.750	2.000	1.020	3/4-16	1.500	0.125	1.187	0.980	0.030
VLRE-4-1/2	95986	4.500	2.000	3.000	1.000	1.250	2.500	1.270	1-1/4-12	2.312	0.062	1.750	1.230	0.060
VLRE-5-1/2	95995	5.500	2.000	4.000	1.000	1.250	2.750	1.395	1-1/4-12	2.312	0.062	1.812	1.355	0.060
VLRE-6-1/2	95997	6.500	3.000	5.000	1.500	2.000	4.500	2.375	2-12	3.250	0.062	2.625	2.125	0.060
VLRE-7-1/2	90110	7.500	3.000	6.000	1.500	2.500	5.500	2.625	2-1/2-12	3.625	0.062	3.125	2.875	0.060

Other sizes available on request.

**Flat washer, lock washer, and jam nut available at additional cost. For size, see "N" dimension.

*For stud hex socket size, see page 85.

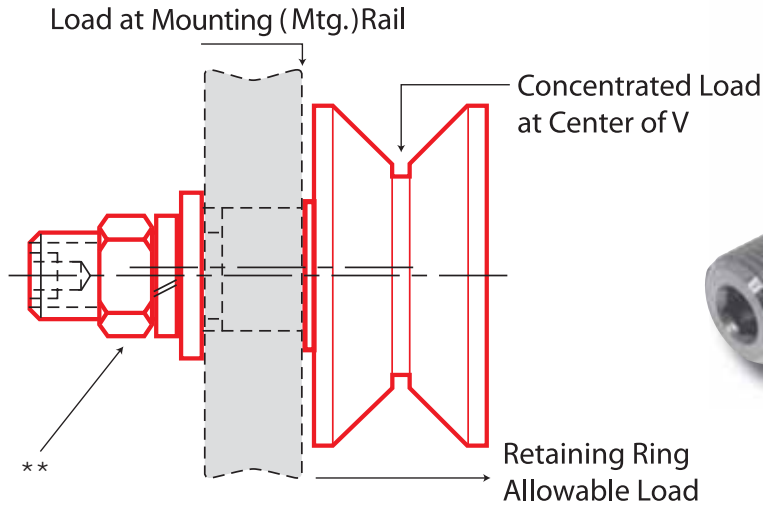

Rec. Mtg. Hole Size	Mounting Member Thickness		Ball or Tapered Roller Bearings	Bearing Capacity Radial Load (lbs)			Bearing Capacity, Static Thrust (lbs)	Stud Capacity (lbs)		Retaining Ring Capacity (lbs)	Approx Weight (lbs)	Part No.
	+0.001 -0.000	Max		Min	3000 hrs L10 life @ 100 RPM	500 hrs L10 life @ 33-1/3 RPM		Static Limit	Bending= 0.75 Sy Bend @V			
0.627	0.625	0.500	BB	240	630	230	140	480	1970	380	0.5	VLRE-1-1/2
0.689	0.750	0.625	BB	520	1350	600	370	920	3250	470	0.6	VLRE-2
1.002	1.000	0.875	BB	1050	2760	1100	680	1230	5780	470	1.4	VLRE-2-1/2
1.189	1.125	1.000	BB	1980	5190	2270	1400	3730	14580	1340	3.4	VLRE-3-1/2
1.189	1.125	1.000	TRB	3780	14270	7200	3150	3120	14580	N/A	3.6	VLRE-3-1/2-4
1.752	1.375	1.250	TRB	6000	14270	20000	12000	12820	40500	N/A	7.3	VLRE-4-1/2
1.814	1.500	1.325	TRB	6000	14270	20000	12000	12820	40500	N/A	10.9	VLRE-5-1/2
2.627	2.500	2.250	TRB	15060	35840	^46030	^23010	37300	103670	N/A	26.5	VLRE-6-1/2
3.127	3.250	3.000	TRB	15060	35840	53860	^26930	72900	161990	N/A	39.5	VLRE-7-1/2

^ Surface strength of roller OD

LOAD CAPACITIES ARE BASED ON UNIFORM AND STEADY LOADING.

Load Runners

Flanged Crown Style - Concentric & Eccentric Stud Style, Inch Sizes

Concentric (FLRC)

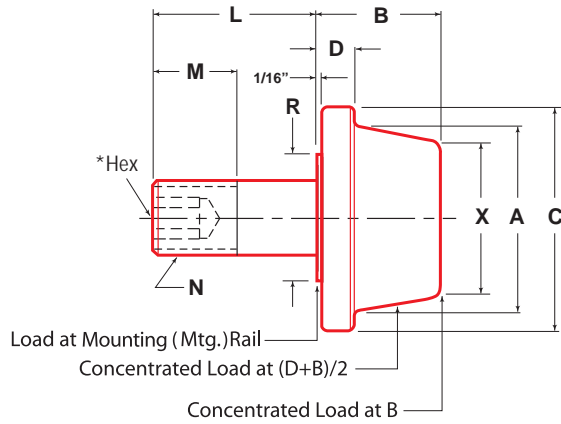

Designed to run on commercially available standard structural I-beams and channels.

Part No.	Item No.	A	B	C	D	K	L	M	N	R	T	U	W	X
		Roller Dia	Roller Width	Flange Dia	Flange Thickness	Stud Dia	Stud Length	Thread Length	Thread	Shoulder Dia	Eccentric Dia	Eccentric Length	Eccentricity	Minor Dia
FLRC-2-1/2	97531	2.500	1.688	3.000	0.500	1.000	2.250	1.500	1-14	1.250	N/A	N/A	N/A	2.062
FLRC-3	97533	3.000	1.812	3.938	0.593	1.000	2.250	1.500	1-14	1.250	N/A	N/A	N/A	2.562
FLRC-4	96057	4.000	2.000	4.938	0.593	1.250	2.750	1.750	1-1/4-12	1.750	N/A	N/A	N/A	3.312
FLRCE-2-1/2	96100	2.500	1.688	3.000	0.500	1.000	2.250	1.145	1-14	1.687	1.375	1.105	0.030	2.062
FLRCE-3	97534	3.000	1.812	3.938	0.593	1.000	2.250	1.145	1-14	1.687	1.375	1.105	0.030	2.562
FLRCE-4	97535	4.000	2.000	4.938	0.593	1.250	2.750	1.395	1-1/4-12	2.312	1.812	1.355	0.060	3.312

Other sizes available on request.

**Flat washer, lock washer, and jam nut available at additional cost. For size, see "N" dimension.

*For stud hex socket size, see page 85.

Eccentric (FLRCE)

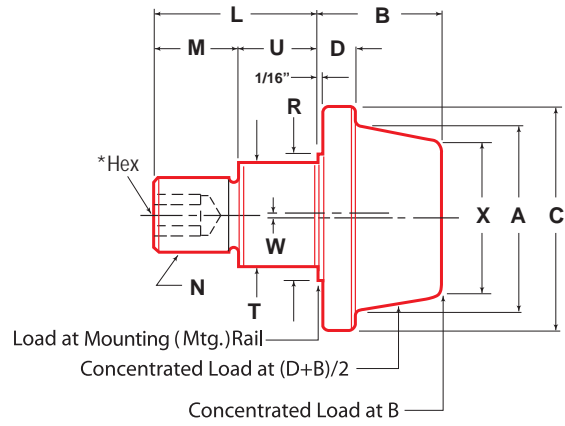

Rec. Mtg. Hole Size	Mounting Member Thickness		Ball or Tapered Roller Bearings	Bearing Capacity Radial Load (lbs)			Bearing Capacity, Static Thrust (lbs)	Stud Capacity (lbs)			Retaining Ring Capacity (lbs)	Approx Weight (lbs)	Part No.
				3000 hrs L10 life @ 100 RPM	500 hrs L10 life @ 33-1/3 RPM	Static Limit		Bending=0.75 Sy		Shear=0.75 x 0.5 x Sy			
								Concent. Load @ (D+B)/2	Concent. Load @ B				
1.001	1.250	0.750	BB	1980	5190	2270	1400	3930	1770	14580	1340	2.8	FLRC-2-1/2
1.001	1.250	0.750	TRB	4570	10890	7630	4570	6760	3520	25920	N/A	4.7	FLRC-3
1.251	1.250	1.000	TRB	6000	14270	20000	12000	13620	6330	40500	N/A	7.9	FLRC-4
1.377	1.250	1.125	BB	1980	5190	2270	1400	3930	1770	14580	1340	3.0	FLRCE-2-1/2
1.377	1.250	1.125	TRB	4570	10890	7630	4570	6760	3520	25920	N/A	5.1	FLRCE-3
1.814	1.500	1.375	TRB	6000	14270	20000	12000	13620	6330	40500	N/A	8.5	FLRCE-4

For the above load calculations the radius at the end of tread is excluded.

Load Runners

Double Flanged - Concentric Stud Style, Inch Sizes

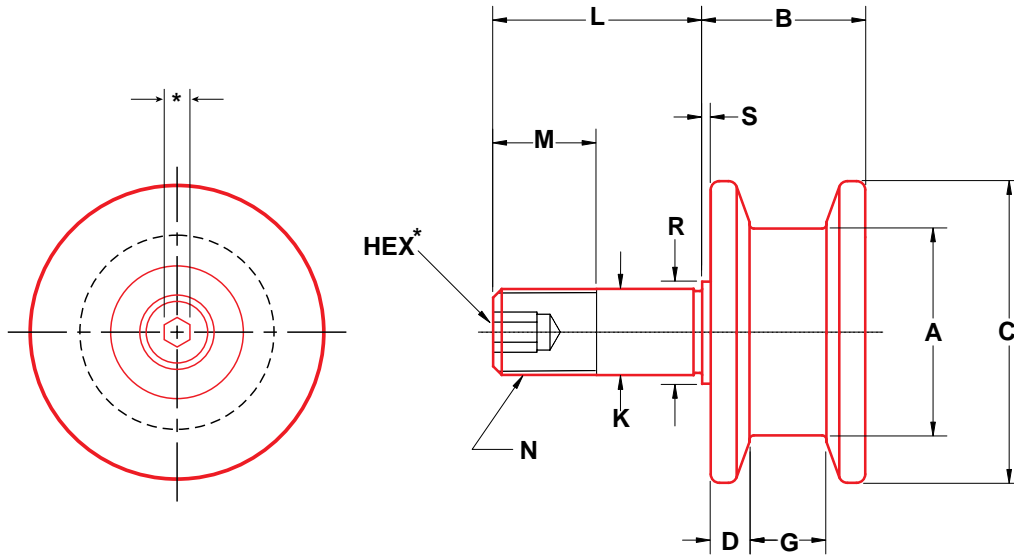

Part No.	Item No.	A	B	C	D	G	K	L	M	N	R	S
		Roller Dia	Roller Width	Flange Dia	Flange Thickness (Both Sides)	Groove Width	Stud Dia +0.000 -0.001	Stud Length	Thread Length	Thread	Shoulder Dia	Shoulder Length
FFLR-1-1/2-4	90670	1.500	1-3/16	2-3/16	0.281	0.558	0.625	1-1/2	3/4	5/8-18	3/4	1/16
FFLR-2-4	90671	2.000	1-11/16	2-11/16	0.531	0.558	0.875	2	1-1/8	7/8-14	1	1/16
FFLR-2-1/2-4	90672	2.500	1-11/16	3-3/16	0.531	0.562	1.000	2-1/4	1-1/2	1-14	1-1/4	1/16
FFLR-3-4	90673	3.000	2	3-15/16	0.531	0.874	1.250	2-1/2	1-3/4	1-1/4-12	1-3/4	1/16

Other sizes available on request.
 Assemblies are provided with jam nuts and lock washers.
 *For stud hex socket size, see page 85.



Rec. Mtg. Hole Size	Mounting Member Thickness		Ball or Tapered Roller Bearings	Bearing Capacity Radial Load (lbs)			Thrust Capacity, Static Limit (lbs)	Stud Capacity (lbs)	Retaining Ring Capacity (lbs)	Approx Weight (lbs)	Part No.
	+0.001 -0.000	Max		Min	3000 hrs L10 life @ 100 RPM	500 hrs L10 life @ 33 1/3 RPM					
0.626	1	3/4	BB	1050	2760	1100	680	1374	470	0.9	FFLR-1-1/2-4
0.876	1-1/4	7/8	BB	1460	3826	1620	1000	3984	910	2.3	FFLR-2-4
1.001	1-1/4	3/4	BB	1979	5187	2268	1400	3694	1340	3.5	FFLR-2-1/2-4
1.251	1-1/4	1	TRB	5990	14270	12263	12000	12260	N/A	6.0	FFLR-3-4

LOAD CAPACITIES ARE BASED ON UNIFORM AND STEADY LOADING.

Load Runners

Stainless Steel

Concentric Stud Plain Style, Flanged, V-Grooved - Inch Sizes

Use where corrosive or other conditions make standard steel rollers unsuitable.

- All-stainless construction
- Corrosion resistant
- Tread 440C & hardened to 55-60Rc
- Stud & cap 300 grade stainless steel

Applications:

- Chemical Treatment
- Tank Building
- Food Processing
- Aerospace
- Marine
- Waste Treatment
- Pharmaceutical

Plain Concentric Stud

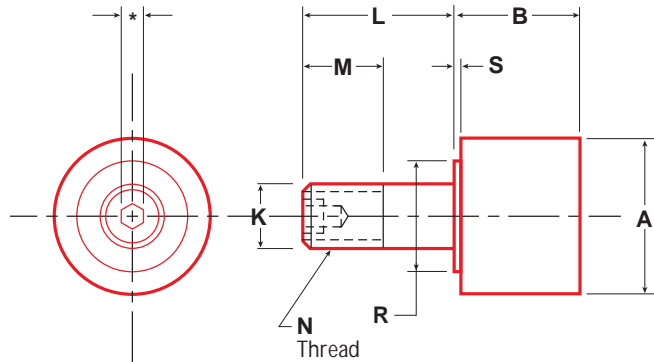

PLAIN

Part No.	Item No.	A	B	K	L	M	N	R	S
		Roller Dia	Roller Width	Stud Dia	Stud Length	Thread Length	Thread	Shoulder Dia	Shoulder Length
		+0.000 -0.001		+0.000 -0.001					
PLRS 1	97734	1.000	0.781	0.437	1.000	0.500	7/16"-20	0.500	0.031
PLRS 1-1/4	97735	1.250	0.844	0.500	1.250	0.625	1/2"-20	0.625	0.031
PLRS 1-1/2	97736	1.500	1.187	0.625	1.500	0.750	5/8"-18	0.750	0.062
PLRS 1-3/4	90341	1.750	1.187	0.750	1.750	0.875	3/4"-16	1.000	0.062
PLRS 2	97737	2.000	1.687	0.875	2.000	1.125	7/8"-14	1.000	0.062
PLRS 2-1/2	97738	2.500	1.687	1.000	2.250	1.500	1"-14	1.250	0.062

FLANGED

Part No.	Item No.	A	B	C	D	K	L	M	N	R	S
		Roller Dia	Roller Width	Flange Dia	Flange Thickness	Stud Dia	Stud Length	Thread Length	Thread	Shoulder Dia	Shoulder Length
		+0.000 -0.001	+0.000 -0.001								
FLRS 1	97739	1.000	0.781	1.375	0.219	0.437	1.000	0.500	7/16"-20	0.500	0.031
FLRS 1-1/4	97740	1.250	0.844	1.563	0.219	0.500	1.250	0.625	1/2"-20	0.625	0.031
FLRS 1-1/2	97741	1.500	1.188	2.188	0.343	0.625	1.500	0.750	5/8"-18	0.750	0.062
FLRS 2	97742	2.000	1.688	2.688	0.593	0.875	2.000	1.125	7/8"-14	1.000	0.062
FLRS 2-1/2	97743	2.500	1.688	3.188	0.593	1.000	2.250	1.500	1"-14	1.250	0.062

V-GROOVED

Part No.	Item No.	A	B	F	G	K	L	M	N	R	S
		Roller Dia	Roller Width	Point Dia	Groove Location	Stud Dia	Stud Length	Thread Length	Thread	Shoulder Dia	Shoulder Length
		+0.000 -0.001	+0.000 -0.001								
VLRS 1-1/2	97994	1.5	0.781	1.125	0.391	0.437	1	0.5	7/16"-20	0.5	0.031
VLRS 2	97995	2	0.844	1.375	0.422	0.5	1.25	0.625	1/2"-20	0.625	0.031
VLRS 2-1/2	97996	2.5	1.312	1.5	0.687	0.75	1.75	0.875	3/4"-16	1	0.062

* Stainless steel assemblies are provided with lock washer and jam nut.

Flanged Concentric Stud

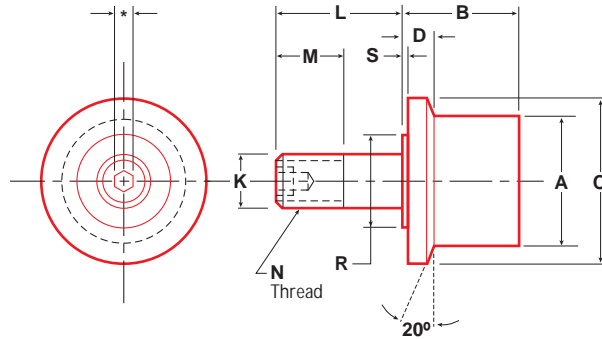

V-Grooved Concentric Stud

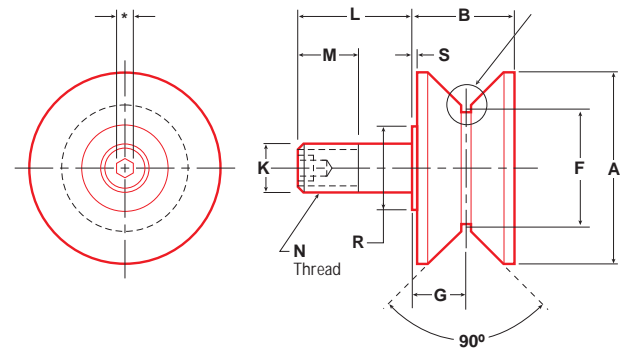

See page 11 for details of design recommendations for roller on rail.

PLAIN

Rec. Mtg. Hole Size	Mounting Member Thickness		Bearing Capacity Radial Load (lbs)			Thrust Capacity, Static Limit (lbs)	Stud Capacity (lbs)			Retaining Ring Capacity (lbs)	Approx Weight (lbs)	Part No.
			3000 hrs L10 life @ 100 RPM	500 hrs L10 life @ 33-1/3 RPM	Radial Static Limit		Bending=0.75 Sy		Shear= 0.75 x 0.5 x Sy			
							Bend @ B/2	Bend @ End of Roller				
+0.001 -0.000	Max	Min										
0.438	0.625	0.500	350	920	390	240	190	80	780	150	0.3	PLRS 1
0.501	0.750	0.625	480	1250	520	320	350	160	1290	230	0.3	PLRS 1-1/4
0.626	1.000	0.750	940	2470	1110	690	550	260	2300	350	0.5	PLRS 1-1/2
0.751	1.125	0.875	940	2470	1110	690	550	260	2300	350	0.8	PLRS 1-3/4
0.876	1.250	0.875	1330	3480	1750	1080	1590	600	4620	740	1.3	PLRS 2
1.001	1.250	0.750	1330	3480	1750	1080	1590	600	4620	740	2.3	PLRS 2-1/2

FLANGED

Rec. Mtg. Hole Size	Mounting Member Thickness		Bearing Capacity Radial Load (lbs)			Thrust Capacity, Static Limit (lbs)	Stud Capacity (lbs)			Retaining Ring Capacity (lbs)	Approx Weight (lbs)	Part No.
			3000 hrs L10 life @ 100 RPM	500 hrs L10 life @ 33-1/3 RPM	Radial Static Limit		Bending=0.75 Sy		Shear= 0.75 x 0.5 x Sy			
							Bend @ (D+B)/2	Bend @ End of Roller				
+0.001 -0.000	Max	Min										
0.438	0.625	0.500	350	920	390	240	150	80	780	150	0.4	FLRS 1
0.501	0.750	0.625	480	1250	520	320	280	160	1290	230	0.5	FLRS 1-1/4
0.626	1.000	0.750	940	2470	1110	690	440	260	2300	350	0.8	FLRS 1-1/2
0.876	1.250	0.875	1330	3480	1750	1080	1050	600	4620	740	2.0	FLRS 2
1.001	1.250	0.750	1330	3480	1750	1080	1050	600	4620	740	3.0	FLRS 2-1/2

V-GROOVED

Rec. Mtg. Hole Size	Mounting Member Thickness		Bearing Capacity Radial Load (lbs)			Thrust Capacity, Static Limit (lbs)	Stud Capacity (lbs)		Retaining Ring Capacity (lbs)	Approx Weight (lbs)	Part No.
			3000 hrs L10 life @ 100 RPM	500 hrs L10 life @ 33-1/3 RPM	Radial Static Limit		Bending = 0.75 Sy @ Center of Roller	Shear = 0.75 x 0.5 x Sy			
0.438	0.75	0.625	350	920	390	240	200	780	150	0.6	VLRS 1-1/2
0.5	0.875	0.75	480	1250	520	320	370	1290	230	0.8	VLRS 2
0.751	1.25	1	940	2470	1110	690	490	2300	350	1.6	VLRS 2-1/2

LOAD CAPACITIES ARE BASED ON UNIFORM AND STEADY LOADING.

Other sizes available on request.

*For stud hex socket size, see page 85.

Load Runners

Stainless Steel

Eccentric Stud Plain Style, Flanged, V-Grooved - Inch Sizes

Use where corrosive or other conditions make standard steel rollers unsuitable.

- All-stainless construction
- Corrosion resistant
- Tread 440C & hardened to 55-60Rc
- Stud & cap 300 grade stainless steel

Applications:

- Chemical Treatment
- Tank Building
- Food Processing
- Aerospace
- Marine
- Waste Treatment
- Pharmaceutical

Plain Eccentric Stud

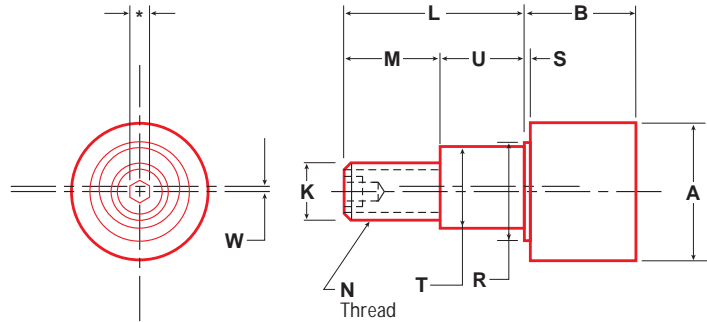

PLAIN

Part No.	Item No.	A	B	K	L	M	N	R	S	T	U	W
		Roller Dia	Roller Width							Eccentric Dia	Eccentric Length	
		+0.000 -0.001								+0.001 -0.001	+0.000 -0.010	
PLRSE 1	97896	1.000	0.781	0.437	1.000	0.500	7/16"-20	0.750	0.031	0.625	0.500	0.030
PLRSE 1-1/4	97897	1.250	0.844	0.500	1.250	0.625	1/2"-20	0.812	0.031	0.687	0.625	0.030
PLRSE 1-1/2	97898	1.500	1.188	0.625	1.500	0.770	5/8"-18	1.125	0.062	0.875	0.730	0.030
PLRSE 1-3/4	90241	1.750	1.188	0.750	1.750	0.875	3/4"-16	1.240	0.062	1.000	0.855	0.030
PLRSE 2	97899	2.000	1.688	0.875	2.000	1.020	7/8"-14	1.500	0.062	1.187	0.980	0.030
PLRSE 2-1/2	97900	2.500	1.688	1.000	2.250	1.145	1"-14	1.687	0.062	1.375	1.105	0.030

FLANGED

Part No.	Item No.	A	B	C	D	K	L	M	N	R	S	T	U	W
		Roller Dia	Roller Width	Flange Dia	Flange Thickness							Eccentric Dia	Eccentric Length	
												+0.001 -0.001	+0.000 -0.010	
FLRSE 1	97965	1.000	0.781	1.375	0.219	0.437	1.000	0.500	7/16"-20	0.750	0.031	0.625	0.500	0.030
FLRSE 1-1/4	97966	1.250	0.844	1.563	0.219	0.500	1.250	0.625	1/2"-20	0.812	0.031	0.687	0.625	0.030
FLRSE 1-1/2	97967	1.500	1.188	2.188	0.343	0.625	1.500	0.770	5/8"-18	1.125	0.062	0.875	0.730	0.030
FLRSE 2	97968	2.000	1.688	2.688	0.593	0.875	2.000	1.020	7/8"-14	1.500	0.062	1.187	0.980	0.030
FLRSE 2-1/2	97969	2.500	1.688	3.188	0.593	1.000	2.250	1.145	1"-14	1.687	0.062	1.375	1.105	0.030

V-GROOVED

Part No.	Item No.	A	B	F	G	K	L	M	N	R	S	T	U	W
		Roller Dia	Roller Width	Point Dia	Groove Location							Eccentric Dia	Eccentric Length	
												+0.001 -0.001	+0.000 -0.010	
VLRSE 1-1/2	97997	1.500	0.781	1.125	0.391	0.437	1.000	0.500	7/16"-20	0.750	0.031	0.625	0.500	0.03
VLRSE 2	97998	2.000	0.844	1.375	0.422	0.5	1.250	0.625	1/2"-20	0.812	0.031	0.687	0.625	0.03
VLRSE 2-1/2	97999	2.500	1.312	1.500	0.687	0.75	1.750	0.875	3/4"-16	1.240	0.062	1.000	0.855	0.03

* Stainless steel assemblies are provided with lock washer and jam nut.

Flanged Eccentric Stud

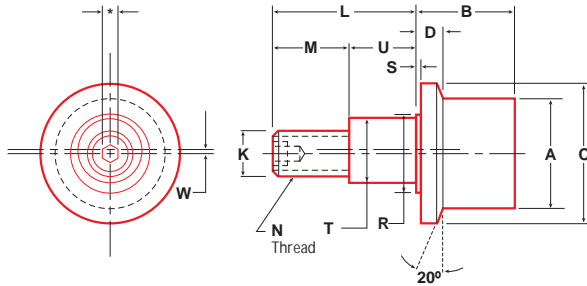

V-Grooved Eccentric Stud

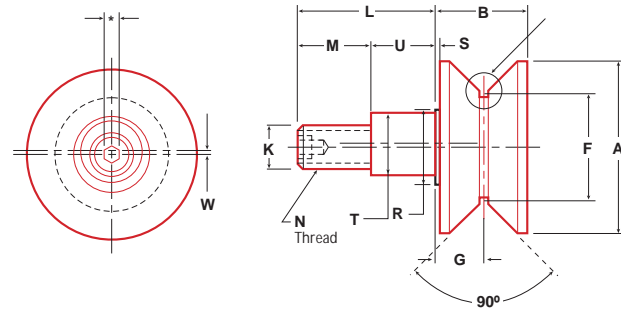

See page 11 for details of design recommendations for roller on rail.

PLAIN

Rec. Mtg. Hole Size	Mounting Member Thickness		Bearing Capacity Radial Load (lbs)			Thrust Capacity, Static Limit (lbs)	Stud Capacity (lbs)			Retaining Ring Capacity (lbs)	Approx Weight (lbs)	Part No.
			3000 hrs L10 life @ 100 RPM	500 hrs L10 life @33-1/3 RPM	Radial Static Limit		Bending=0.75 Sy		Shear= 0.75 x 0.5 x Sy			
							Bend @ B/2	Bend @ End of Roller				
+0.001 -0.000	Max	Min										
0.627	0.625	0.500	350	920	390	240	190	80	780	150	0.4	PLRSE 1
0.689	0.750	0.625	480	1250	520	320	350	160	1290	230	0.5	PLRSE 1-1/4
0.877	0.875	0.750	940	2470	1110	690	550	260	2300	350	0.7	PLRSE 1-1/2
1.002	1.000	0.875	940	2470	1110	690	550	260	2300	350	1.0	PLRSE 1-3/4
1.189	1.125	1.000	1330	3480	1750	1080	1610	600	4620	740	1.9	PLRSE 2
1.377	1.250	1.125	1330	3480	1750	1080	1600	600	4620	740	3.0	PLRSE 2-1/2

FLANGED

Rec. Mtg. Hole Size	Mounting Member Thickness		Bearing Capacity Radial Load (lbs)			Thrust Capacity, Static Limit (lbs)	Stud Capacity (lbs)			Retaining Ring Capacity (lbs)	Approx Weight (lbs)	Part No.
			3000 hrs L10 life @ 100 RPM	500 hrs L10 life @33-1/3 RPM	Radial Static Limit		Bending=0.75 Sy		Shear= 0.75 x 0.5 x Sy			
							Bend @ (D+B)/2	Bend @ End of Roller				
+0.001 -0.000	Max	Min										
0.627	0.625	0.500	350	920	390	240	150	80	780	150	0.5	FLRSE 1
0.689	0.750	0.625	480	1250	520	320	280	160	1290	230	0.7	FLRSE 1-1/4
0.877	0.875	0.750	940	2470	1110	690	440	260	2300	350	0.8	FLRSE 1 -1/2
1.189	1.125	1.000	1330	3480	1750	1080	1050	600	4620	740	2.0	FLRSE 2
1.377	1.250	1.125	1330	3480	1750	1080	1060	600	4620	740	3.0	FLRSE 2-1/2

V-GROOVED

Rec. Mtg. Hole Size	Mounting Member Thickness		Bearing Capacity Radial Load (lbs)			Thrust Capacity, Static Limit (lbs)	Stud Capacity (lbs)		Retaining Ring Capacity (lbs)	Approx Weight (lbs)	Part No.
			3000 hrs L10 life @ 100 RPM	500 hrs L10 life @33-1/3 RPM	Radial Static Limit		Bending = 0.75 Sy @ Center of V	Shear = 0.75 x 0.5 x Sy			
0.627	0.625	0.500	350	920	390	240	190	780	150	1.0	VLRSE 1-1/2
0.689	0.750	0.625	480	1250	520	320	370	1290	230	1.2	VLRSE 2
1.002	1.000	0.875	940	2470	1110	690	490	2300	350	1.6	VLRSE 2-1/2

*For stud hex socket size, see page 85.

LOAD CAPACITIES ARE BASED ON UNIFORM AND STEADY LOADING.

Load Runners

High Temp Load Runners

Plain Style, Flanged, V-Grooved - Inch Sizes

For ovens, galvanizing lines, heat treat furnaces, and industrial dryers.

- Resists 325°F Max (continuous) High Temp Seals and Lubricants

Applications:

- Paper Mills
- Steel Mills
- Aluminum Mills
- Foundries
- Food Processing
- Aerospace

Plain Concentric Stud

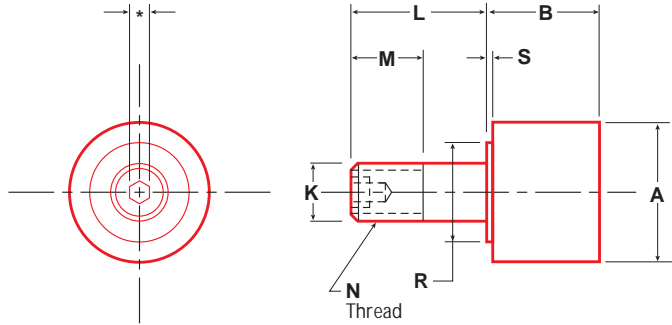

PLAIN

Part No.	Item No.	A	B	K	L	M	N	R	S
		Roller Dia	Roller Width	Stud Dia	Stud Length	Thread Length	Thread	Shoulder Dia	Shoulder Length
		+0.000 -0.001		+0.000 -0.001					
PLRH 1	97724	1.000	0.781	0.437	1.000	0.500	7/16"-20	0.500	0.031
PLRH 1-1/4	97725	1.250	0.844	0.500	1.250	0.625	1/2"-20	0.625	0.031
PLRH 1-1/2	97726	1.500	1.187	0.625	1.500	0.750	5/8"-18	0.750	0.062
PLRH 2	97727	2.000	1.687	0.875	2.000	1.125	7/8"-14	1.000	0.062
PLRH 2-1/2	97728	2.500	1.687	1.000	2.250	1.500	1"-14	1.250	0.062

FLANGED

Part No.	Item No.	A	B	C	D	K	L	M	N	R	S
		Roller Dia	Roller Width	Flange Dia	Flange Thickness	Stud Dia	Stud Length	Thread Length	Thread	Shoulder Dia	Shoulder Length
		+0.000 -0.001	+0.000 -0.001								
FLRH 1	97729	1.000	0.781	1.375	0.219	0.437	1.000	0.500	7/16"-20	0.500	0.031
FLRH 1-1/4	97730	1.250	0.844	1.563	0.219	0.500	1.250	0.625	1/2"-20	0.625	0.031
FLRH 1-1/2	97731	1.500	1.188	2.188	0.343	0.625	1.500	0.750	5/8"-18	0.750	0.062
FLRH 2	97732	2.000	1.688	2.688	0.593	0.875	2.000	1.125	7/8"-14	1.000	0.062
FLRH 2-1/2	97733	2.500	1.688	3.188	0.593	1.000	2.250	1.500	1"-14	1.250	0.062

V-GROOVED

Part No.	Item No.	A	B	F	G	K	L	M	N	R	S
		Roller Dia	Roller Width	Point Dia	Groove Location	Stud Dia	Stud Length	Thread Length	Thread	Shoulder Dia	Shoulder Length
		+0.000 -0.001	+0.000 -0.001								
VLRH 1-1/2	90048	1.50	0.781	1.125	0.391	0.437	1.00	0.500	7/16-20	0.500	0.031
VLRH 2	90072	2.00	0.844	1.375	0.422	0.50	1.25	0.625	1/2-20	0.625	0.031
VLRH 2-1/2	90049	2.50	1.312	1.500	0.687	0.75	1.75	0.875	3/4-16	1.000	0.062

High temp assemblies provided with jam nuts and lock washers.

*For stud hex socket size, see page 85.

Flanged Concentric Stud

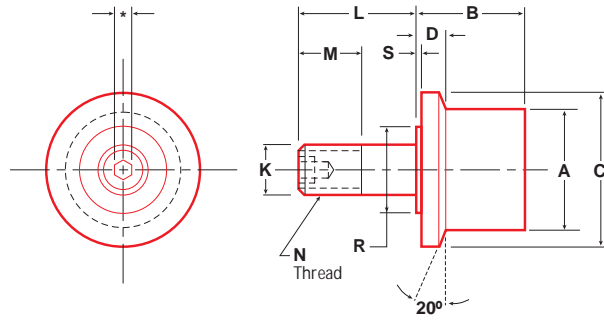

V-Grooved Concentric Stud

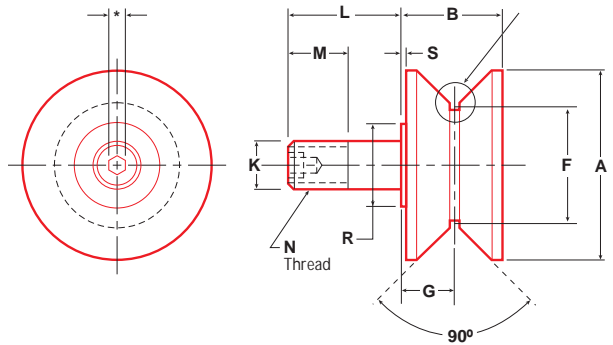

See page 11 for details of design recommendations for roller on rail.

PLAIN

Rec. Mtg. Hole Size	Mounting Member Thickness		Bearing Capacity Radial Load (lbs)			Thrust Capacity, Static Limit (lbs)	Stud Capacity (lbs)			Retaining Ring Capacity (lbs)	Approx Weight (lbs)	Part No.
			3000 hrs L10 life @ 100 RPM	500 hrs L10 life @ 33-1/3 RPM	Radial Static Limit		Bending=0.75 Sy		Shear=0.75 x 0.5 x Sy			
							Bend @ End of Roller	Bend @ B/2				
+0.001 -0.000	Max	Min										
0.438	0.625	0.500	350	920	390	240	210	480	1970	380	0.2	PLRH 1
0.501	0.750	0.625	480	1250	520	320	390	880	3250	470	0.3	PLRH 1-1/4
0.626	1.000	0.750	940	2470	1110	690	650	1390	5780	470	0.4	PLRH 1-1/2
0.876	1.250	0.875	1330	3480	1750	1080	1500	4010	11610	910	1.3	PLRH 2
1.001	1.250	0.750	1330	3480	1750	1080	1500	4010	11610	910	2.3	PLRH 2-1/2

FLANGED

Rec. Mtg. Hole Size	Mounting Member Thickness		Bearing Capacity Radial Load (lbs)			Thrust Capacity, Static Limit (lbs)	Stud Capacity (lbs)			Retaining Ring Capacity (lbs)	Approx Weight (lbs)	Part No.
			3000 hrs L10 life @ 100 RPM	500 hrs L10 life @ 33 1/3 RPM	Radial Static Limit		Bending=0.75 Sy		Shear=0.75 x 0.5 x Sy			
							Bend @ End of Roller	Bend @ D+B/2				
+0.001 -0.000	Max	Min										
0.438	0.625	0.500	350	920	390	240	210	370	1970	380	0.3	FLRH 1
0.501	0.750	0.625	480	1250	520	320	390	710	3250	470	0.4	FLRH 1-1/4
0.626	1.000	0.750	940	2470	1110	690	810	1100	5780	470	0.6	FLRH 1-1/2
0.876	1.250	0.875	1330	3480	1750	1080	1500	2640	11610	910	1.8	FLRH 2
1.001	1.250	0.750	1330	3480	1750	1080	1500	2650	11610	910	2.8	FLRH 2-1/2

V-GROOVED

Rec. Mtg. Hole Size	Mounting Member Thickness		Bearing Capacity Radial Load (lbs)			Thrust Capacity, Static Limit (lbs)	Stud Capacity (lbs)		Retaining Ring Capacity (lbs)	Approx Weight (lbs)	Part No.
			3000 hrs L10 life @ 100 RPM	500 hrs L10 life @ 33-1/3 RPM	Radial Static Limit		Bending = 0.75 Sy @ Center of V	Shear = 0.75 x 0.5 x Sy			
0.438	0.750	0.625	350	920	390	240	500	1970	380	0.5	VLRH 1-1/2
0.500	0.875	0.750	480	1250	520	320	920	3250	470	0.6	VLRH 2
0.751	1.250	1.000	940	2470	1110	690	1310	6230	470	14	VLRH 2-1/2

LOAD CAPACITIES ARE BASED ON UNIFORM AND STEADY LOADING.

Load Runners

Nylon Tread Load Runners - Concentric & Eccentric - Inch Sizes

Cost-effective performance in applications requiring a non-metallic outer face.

- Seals out contamination
- Non-sparking
- Non-marking

Applications:

- Racking & Storage Retrieval Systems
- Food Processing
- Postal Systems
- Medical Equipment

Concentric Stud Style

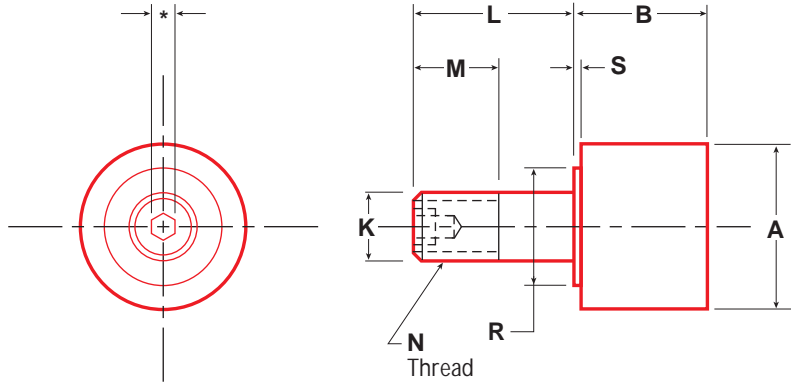

CONCENTRIC STUD STYLE

Part No.	Item No.	A	B	K	L	M	N	R	S
		Roller Dia	Roller Width	Stud Dia	Stud Length	Thread Length	Thread	Shoulder Dia	Shoulder Length
		+0.000 -0.001		+0.000 -0.001					
PLRN-1	97749	1.000	0.781	0.437	1.000	0.500	7/16-20	0.500	0.031
PLRN-1-1/4	97750	1.250	0.844	0.500	1.250	0.625	1/2-20	0.625	0.031
PLRN-1-1/2	97751	1.500	1.187	0.625	1.500	0.750	5/8-18	0.750	0.062
PLRN-2	97752	2.000	1.687	0.875	2.000	1.125	7/8-14	1.000	0.062
PLRN-2-1-2	97753	2.500	1.687	1.000	2.250	1.500	1-14	1.250	0.062

ECCENTRIC STUD STYLE

Part No.	Item No.	A	B	K	L	M	N	R	S	T	U	W
		Roller Dia	Roller Width	Stud Dia	Stud Length	Thread Length	Thread	Shoulder Dia	Shoulder Length	Eccentric Dia	Eccentric Length	Eccentricity
		+0.000 -0.001								+0.001 -0.001	+0.000 -0.010	
PLRNE-1	97891	1.000	0.781	0.437	1.000	0.500	7/16-20	0.750	0.031	0.625	0.500	0.030
PLRNE-1-1/4	97892	1.250	0.844	0.500	1.250	0.625	1/2-20	0.812	0.031	0.687	0.625	0.030
PLRNE-1-1/2	97893	1.500	1.187	0.625	1.500	0.770	5/8-18	1.125	0.062	0.875	0.730	0.030
PLRNE-2	97894	2.000	1.687	0.875	2.000	1.020	7/8-14	1.500	0.062	1.187	0.980	0.030
PLRNE-2-1/2	97895	2.500	1.687	1.000	2.250	1.145	1-14	1.687	0.062	1.375	1.105	0.030

Nylon assemblies provided with jam nut and lock washers.

*For stud hex socket size, see page 85.



Eccentric Stud Style

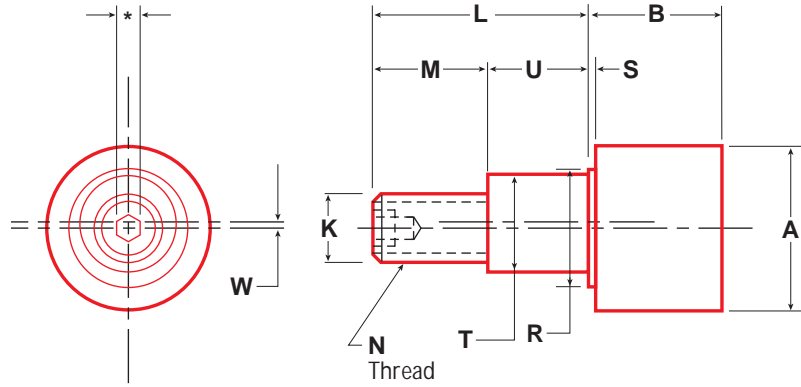

CONCENTRIC STUD STYLE

	Rec. Mtg. Hole Size		Mounting Member Thickness		Bearing Capacity, Radial Load (lbs)			Bearing Capacity, Static Thrust (lbs)	Retaining Ring Capacity (lbs)	Tread Capacity (lbs)	Approx Weight (lbs)	Part No.
	+0.001 -0.000	Max	Min	3000 hrs L10 life @ 100 RPM	500 hrs L10 life @ 33 1/3 RPM	Static Limit						
	0.438	0.625	0.500	240	630	230	140	280	30	0.2	PLRN-1	
	0.501	0.750	0.625	520	1350	600	370	470	40	0.25	PLRN-1-1/4	
	0.626	1.000	0.750	1050	2760	1100	680	470	60	0.5	PLRN-1-1/2	
	0.876	1.250	0.875	1460	3830	1620	1000	910	120	1.1	PLRN-2	
	1.001	1.250	0.750	1980	5190	2270	1400	1340	130	1.6	PLRN-2-1-2	

ECCENTRIC STUD STYLE

	Rec. Mtg. Hole Size		Mounting Member Thickness		Bearing Capacity Radial Load (lbs)			Bearing Static Thrust Capacity (lbs)	Retaining Ring Capacity (lbs)	Tread Capacity (lbs)	Approx Weight (lbs)	Part No.
	+0.001 -0.000	Max	Min	3000 hrs L10 life @ 100 RPM	500 hrs L10 life @ 33 1/3 RPM	Static Limit						
	0.627	0.625	0.500	240	630	230	140	280	30	0.2	PLRNE-1	
	0.689	0.750	0.625	520	1350	600	370	470	40	0.3	PLRNE-1-1/4	
	0.877	0.875	0.750	1050	2760	1100	680	470	60	1.1	PLRNE-1-1/2	
	1.189	1.125	1.000	1460	3830	1620	1000	910	120	1.4	PLRNE-2	
	1.377	1.250	1.125	1980	5190	2270	1400	1340	130	1.9	PLRNE-2-1/2	

LOAD CAPACITIES ARE BASED ON UNIFORM AND STEADY LOADING.

Load Runners

Urethane Tread Concentric - Inch Sizes

Proven in special applications calling for a wear-resistant, non-metallic rolling surface.

- Impact resistant
- Reduced track wear
- Outdoor durability

Applications:

- Medical Equipment
- Construction Sites
- Postage Systems

Concentric Stud Style

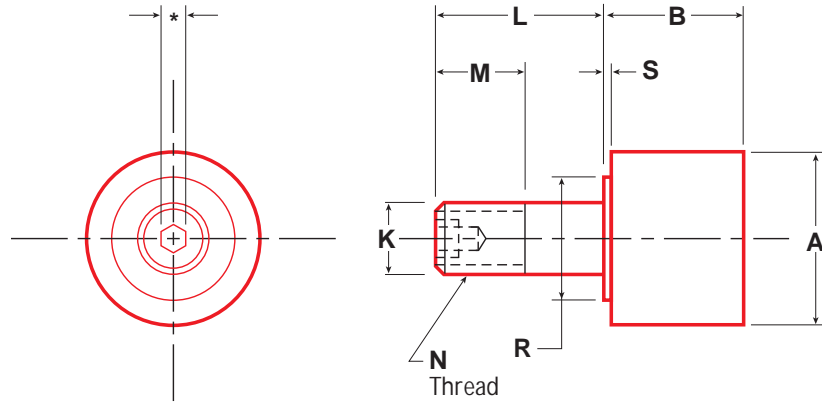

CONCENTRIC

Part No.	Item No.	A Roller Dia	B Roller Width	K Stud Dia +0.000 -0.001	L Stud Length	M Thread Length	N Thread	R Shldr Dia	S Shldr Length	Rec. Mtg. Hole Size +0.001 -0.000	Mounting Member Thickness		Bearing Radial Capacity (lbs) 3000 hrs L10 life @ 100 RPM	Tread Capacity (lbs)	Tread Speed Limit (RPM)	Approx Weight (lbs)
											Max	Min				
PLRU-1	97744	1.000	0.781	0.437	1.000	0.500	7/16-20	0.500	0.031	0.438	0.625	0.500	230	80	300	0.20
PLRU-1-1/8	97824	1.125	0.781	0.437	1.000	0.500	7/16-20	0.500	0.031	0.438	0.625	0.500	230	80	260	0.20
PLRU-1-1/4	97745	1.250	0.843	0.500	1.250	0.625	1/2-20	0.625	0.031	0.501	0.750	0.625	240	110	320	0.30
PLRU-1-3/8	97825	1.375	0.843	0.500	1.250	0.625	1/2-20	0.625	0.031	0.501	0.750	0.625	240	140	310	0.30
PLRU-1-1/2	97746	1.500	1.187	0.625	1.500	0.750	5/8-18	0.750	0.062	0.626	1.000	0.750	520	170	310	0.35
PLRU-1-3/4	97826	1.750	1.187	0.750	1.750	0.875	3/4-16	0.875	0.062	0.751	1.125	0.875	520	250	360	0.70
PLRU-2	97747	2.000	1.687	0.875	2.000	1.125	7/8-14	1.000	0.062	0.876	1.250	0.875	1050	340	360	1.00
PLRU-2-1/4	97827	2.250	1.687	0.875	2.000	1.125	7/8-14	1.000	0.062	0.876	1.250	0.875	1050	430	370	1.50
PLRU-2-1/2	97748	2.500	1.687	1.000	2.250	1.500	1-14	1.250	0.062	1.001	1.250	0.750	1980	410	400	2.00
PLRU-2-3/4	97828	2.750	1.687	1.000	2.250	1.500	1-14	1.250	0.062	1.001	1.250	0.750	1980	420	850	3.00

Urethane rollers include jam nut and lock washer.

*For stud hex socket size, see page 85.

Eccentric Stud Style

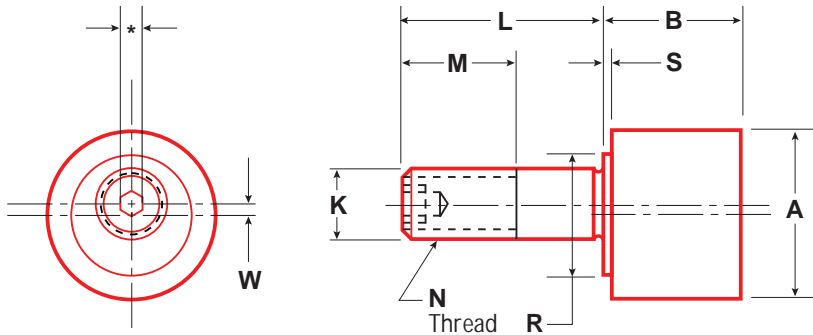

ECCENTRIC

Part No.	Item No.	A	B	K	L	M	N	R	S	W	Rec. Mtg. Hole Size	Mounting Member Thickness		Bearing Radial Capacity (lbs) 3000 hrs L10 life @ 100 RPM	Tread Capacity (lbs)	Tread Speed Limit (RPM)	Approx Weight (lbs)
		Roller Dia	Roller Width	Stud Dia	Stud Length	Thread Length	Thread	Shldr Dia	Shldr Length	Eccentricity		+0.001 -0.000	Max				
PLRUE-1	97881	1.000	0.781	0.437	1.000	0.500	7/16-20	0.500	0.031	0.030	0.439	0.625	0.500	230	80	300	0.30
PLRUE-1/8	97882	1.125	0.781	0.437	1.000	0.500	7/16-20	0.500	0.031	0.030	0.439	0.625	0.500	230	80	260	0.30
PLRUE-1/4	97883	1.250	0.843	0.500	1.250	0.625	1/2-20	0.625	0.031	0.030	0.502	0.750	0.625	240	110	320	0.30
PLRUE-13/8	97884	1.375	0.843	0.500	1.250	0.625	1/2-20	0.625	0.031	0.030	0.502	0.750	0.625	240	140	310	0.30
PLRUE-1/2	97885	1.500	1.187	0.625	1.500	0.750	5/8-18	0.750	0.062	0.030	0.627	1.000	0.750	520	170	310	0.50
PLRUE-13/4	97886	1.750	1.187	0.750	1.750	0.750	3/4-16	0.875	0.062	0.030	0.752	1.125	0.875	520	250	360	1.00
PLRUE-2	97887	2.000	1.687	0.875	2.000	1.125	7/8-14	1.000	0.062	0.030	0.877	1.250	0.875	1050	340	360	1.20
PLRUE-2/4	97888	2.250	1.687	0.875	2.000	1.125	7/8-14	1.000	0.062	0.030	0.877	1.250	0.875	1050	430	370	1.50
PLRUE-2/2	97889	2.500	1.687	1.000	2.250	1.500	1-14	1.250	0.062	0.030	1.002	1.250	0.750	1980	410	400	2.00
PLRUE-23/4	97890	2.750	1.687	1.000	2.250	1.500	1-14	1.250	0.062	0.030	1.002	1.250	0.750	1980	420	850	2.10

Urethane rollers include jam nut and lock washer.

*For stud hex socket size, see page 85.

LOAD CAPACITIES ARE BASED ON UNIFORM AND STEADY LOADING.

Load Runners

Plain Yoke Style - Inch Sizes

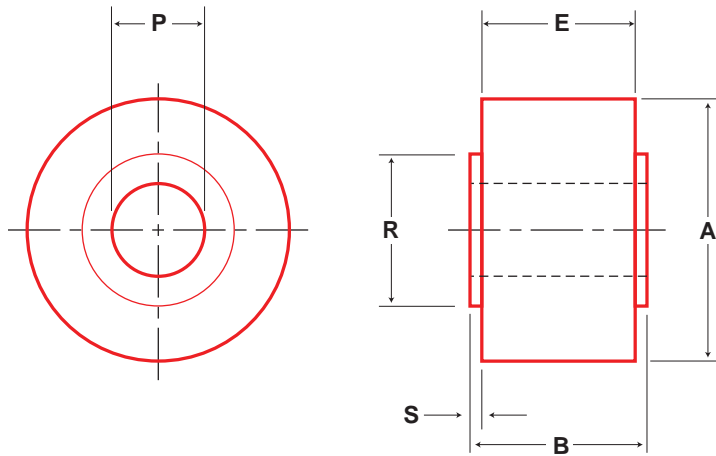

Part No.	Item No.	A		B		E		P		R	S	Ball or Tapered Roller Bearing	Bearing Capacity Radial Load (lbs)			Bearing Static Thrust Capacity (lbs)	Approx Weight (lbs)
		Roller Dia	Roller Width	Tread Width	Bore		Shldr Dia	Shldr Length	3000 hrs L10 life @ 100 RPM				500 hrs L10 life @ 33-1/3 RPM	Static Limit			
		+0.000 -0.001	+0.005 -0.010		Nom	Tol											
PLRY-1-1/2	90254	1.500	0.937	0.875	0.437			0.875	0.031	BB	710	1850	780	480	0.3		
PLRY-1-3/4	90255	1.750	1.063	1.000	0.500			1.000	0.031	BB	710	1850	780	480	0.7		
PLRY-2	90256	2.000	1.313	1.250	0.625			1.125	0.031	BB	1300	3400	1810	1120	0.9		
PLRY-2-1/4	90257	2.250	1.313	1.250	0.625			1.125	0.031	BB	1300	3400	1810	1120	1.4		
PLRY-2-1/2	96117	2.500	1.562	1.500	0.750			1.250	0.031	TRB	4570	10880	7630	4570	2.0		
PLRY-2-1/2-7	90107	2.500	1.562	1.500	0.750			1.250	0.031	BB	2130	5590	2530	1560	2.0		
PLRY-2-3/4-7	90108	2.750	1.562	1.500	0.750			1.250	0.031	BB	2130	5590	2530	1560	2.3		
PLRY-3	96118	3.000	1.812	1.750	1.000			1.750	0.031	TRB	6000	14270	20000	12000	2.6		
PLRY-3-1/4	96133	3.250	1.812	1.750	1.000			1.750	0.031	TRB	6000	14270	20000	12000	3.4		
PLRY-3-1/2	96138	3.500	2.062	2.000	1.125			2.000	0.031	TRB	7390	17590	27200	13100	4.2		
PLRY-4	96144	4.000	2.312	2.250	1.250			2.250	0.031	TRB	7390	17590	27200	13100	6.6		
PLRY-5	96154	5.000	2.875	2.750	1.750		+0.0005 -0.0010	3.250	0.062	TRB	13990	33290	51900	32500	11.3		
PLRY-6	96165	6.000	3.375	3.250	2.250			3.500	0.062	TRB	15060	35840	56400	33100	19.4		
PLRY-7	96177	7.000	3.875	3.750	2.750			4.250	0.062	TRB	17830	42430	79800	48400	29.3		
PLRY-8	96184	8.000	4.500	4.250	3.255			4.750	0.125	TRB	35250	83890	159800	110000	43.9		
PLRY-9	96194	9.000	5.000	4.750	3.755			5.500	0.125	TRB	56400	134230	250000	147000	51.6		
PLRY-10	96197	10.000	5.500	5.250	4.255		+0.001 -0.000	6.500	0.125	TRB	58080	138240	276000	196000	80.0		

Other sizes available upon request
 For HEAVY DUTY SHAFTS see pages 60-61
 Refer to INSTALLATION NOTES on pages 83-85
 LOAD CAPACITIES ARE BASED ON UNIFORM AND STEADY LOADING.

Load Runners Crowned Yoke Style - Inch Sizes

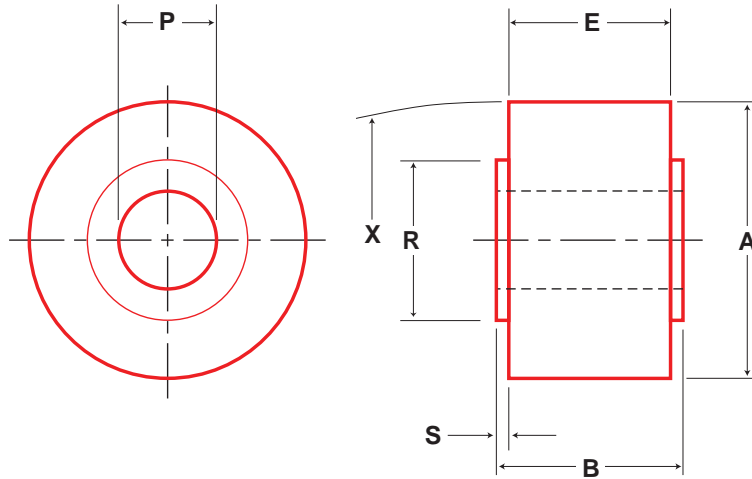

Part No.	Item No.	A	B	E	P		R	S	X	Ball or Tapered Roller Bearing	Bearing Capacity Radial Load (lbs)			Bearing Static Thrust Capacity (lbs)	Approx Weight (lbs)
		Roller Dia	Roller Width	Tread Width	Bore		Shldr Dia	Shldr Length	Crown Radius		3000 hrs L10 life @ 100 RPM	500 hrs L10 life @ 33-1/3 RPM	Static Limit		
		+0.000 -0.001	+0.005 -0.010		Norm	Tol									
CLRY-1-1/2	90265	1.5	0.937	0.875	0.437		0.875	0.031	20	BB	710	1850	780	480	0.3
CLRY-1-3/4	90266	1.750	1.063	1.000	0.500		1.000	0.031	20	BB	710	1850	780	480	0.7
CLRY-2	90267	2.000	1.313	1.250	0.625		1.125	0.031	24	BB	1300	3400	1810	1120	0.9
CLRY-2-1/4	90268	2.250	1.313	1.250	0.625		1.125	0.031	24	BB	1300	3400	1810	1120	1.4
CLRY-2-1/2	90269	2.500	1.562	1.500	0.750		1.250	0.031	30	TRB	4570	10880	7630	4570	2.0
CLRY-2-1/2-7	90270	2.500	1.562	1.500	0.750		1.250	0.031	30	BB	2130	5590	2530	1560	2.0
CLRY-3	96307	3.000	1.812	1.750	1.000		1.750	0.031	30	TRB	6000	14270	^13030	12000	2.6
CLRY-3-1/4	97204	3.250	1.812	1.750	1.000		1.750	0.031	30	TRB	6000	14270	^14120	12000	3.4
CLRY-3-1/2	97568	3.500	2.062	2.000	1.125		2.000	0.031	30	TRB	7390	17590	^15200	13100	4.2
CLRY-4	96312	4.000	2.312	2.250	1.250		2.250	0.031	30	TRB	7390	17590	^17730	13100	6.6
CLRY-5	97569	5.000	2.875	2.750	1.750		3.250	0.062	48	TRB	13990	33290	^27450	^27450	11.3
CLRY-6	96320	6.000	3.375	3.250	2.250	+0.0005 -0.0000	3.500	0.062	56	TRB	15060	35840	^35610	33100	19.4
CLRY-7	97570	7.000	3.875	3.750	2.750		4.250	0.062	60	TRB	17830	42430	^43000	^43000	29.3
CLRY-8	96327	8.000	4.500	4.250	3.255		4.750	0.125	40	TRB	35250	83890	^40110	^40110	43.9
CLRY-9	97571	9.000	5.000	4.750	3.755	+0.000 -0.000	5.500	0.125	40	TRB	56400	134230	^45130	^45130	51.6
CLRY-10	97572	10.000	5.500	5.250	4.255		6.500	0.125	40	TRB	58080	138240	^50140	^50140	80.0

^Surface strength of roller OD

Other sizes available upon request
 For HEAVY DUTY SHAFTS see pages 60-61
 Refer to INSTALLATION NOTES on pages 83-85
 LOAD CAPACITIES ARE BASED ON UNIFORM AND STEADY LOADING.

Load Runners

Flanged Yoke Style - Inch Sizes

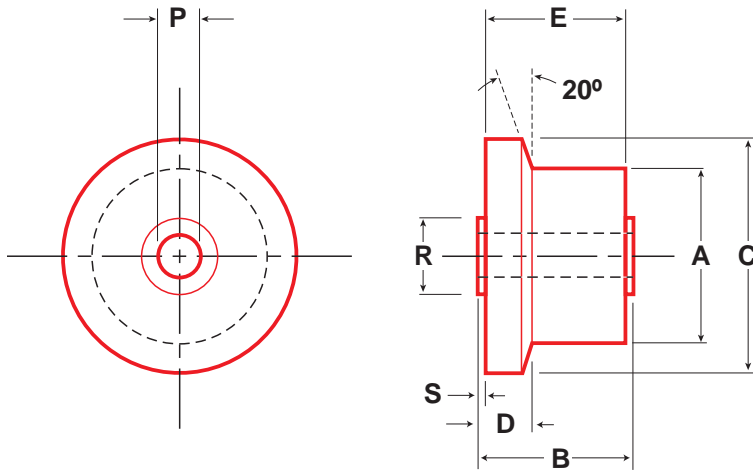

Part No.	Item No.	A	B	C	D	E	P		R	S	Ball or Tapered Roller Bearing	Bearing Capacity Radial Load (lbs)			Bearing Static Thrust Capacity (lbs)	Approx Weight (lbs)
		Roller Dia	Roller Width	Flange Dia	Flange Thickness	Tread Width	Bore		Shldr Dia	Shldr Length		3000 hrs L10 life @ 100 RPM	500 hrs L10 life @ 33-1/3 RPM	Static Limit		
			+0.005 -0.010				Nom	Tol								
FLRY-1-1/2	90258	1.500	0.937	2.188	0.218	0.872	0.437	+0.0005 -0.0000	0.875	0.031	BB	710	1850	780	480	0.4
FLRY-1-3/4	90259	1.750	1.063	2.438	0.250	1.000	0.500		1.000	0.031	BB	710	1850	780	480	0.8
FLRY-2	90260	2.000	1.313	2.688	0.312	1.250	0.625		1.125	0.031	BB	1300	3400	1810	1120	1.4
FLRY-2-1/4	90261	2.250	1.313	2.938	0.312	1.250	0.625		1.125	0.031	BB	1300	3400	1810	1120	1.7
FLRY-2-1/2	96652	2.500	1.562	3.187	0.500	1.500	0.750		1.250	0.031	TRB	4570	10880	7630	4570	2.4
FLRY-2-1/27	90105	2.500	1.562	3.187	0.500	1.500	0.750		1.250	0.031	BB	2130	5590	2530	1560	2.4
FLRY-2-3/47	90106	2.750	1.562	3.437	0.500	1.500	0.750		1.250	0.031	BB	2130	5590	2530	1560	2.9
FLRY-3	96220	3.000	1.812	3.937	0.590	1.750	1.000		1.750	0.031	TRB	6000	14270	20000	12000	3.5
FLRY-3-1/4	96225	3.250	1.812	4.187	0.590	1.750	1.000		1.750	0.031	TRB	6000	14270	20000	12000	4.3
FLRY-3-1/2	96227	3.500	2.062	4.437	0.590	2.000	1.125		2.000	0.031	TRB	7390	17590	27200	13100	5.2
FLRY-4	96229	4.000	2.312	4.937	0.590	2.250	1.250	2.250	0.031	TRB	7390	17590	27200	13100	7.7	
FLRY-5	96231	5.000	2.875	5.937	0.720	2.750	1.750	3.500	0.062	TRB	13990	33290	^50020	32500	12.9	
FLRY-6	96237	6.000	3.375	6.937	0.720	3.250	2.250	3.500	0.062	TRB	15060	35840	56400	33100	21.4	
FLRY-7	96241	7.000	3.875	7.937	0.720	3.750	2.750	4.250	0.062	TRB	17830	42430	79800	48400	31.7	
FLRY-8	96243	8.000	4.500	8.937	0.720	4.250	3.255	4.750	0.125	TRB	35250	83890	159800	110000	46.6	
FLRY-9	96246	9.000	5.000	9.937	0.720	4.750	3.755	5.500	0.125	TRB	56400	134230	^225560	147000	54.6	
FLRY-10	96250	10.000	5.500	10.937	0.720	5.250	4.255	6.500	0.125	TRB	58080	138240	276000	196000	83.4	

^Surface strength of roller OD

Other sizes available upon request
 For HEAVY DUTY SHAFTS see pages 60-61
 Refer to INSTALLATION NOTES on pages 83-85
 LOAD CAPACITIES ARE BASED ON UNIFORM AND STEADY LOADING.

Load Runners V-Grooved Yoke Style - Inch Sizes

See page 11 for details of design recommendations for roller on rail.

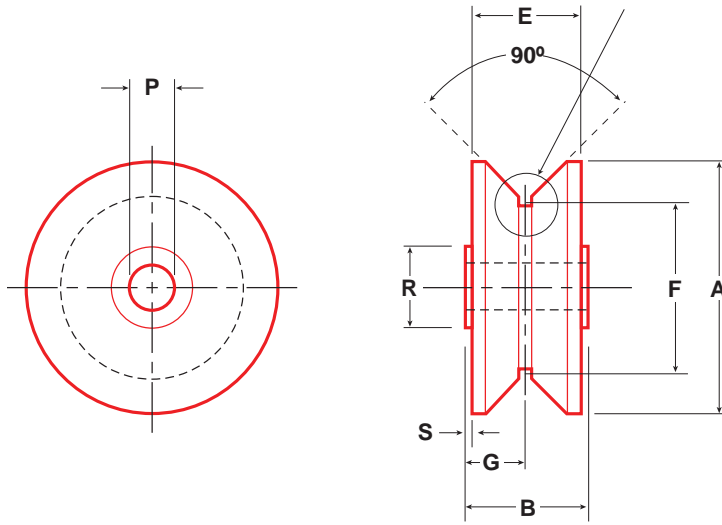

Part No.	Item No.	A	B	E	F	G	P		R	S	Ball or Tapered Roller Bearing	Bearing Capacity Radial Load (lbs)			Bearing Static Thrust Capacity (lbs)	Approx Weight (lbs)
							Bore					3000 hrs L10 life @ 100 RPM	500 hrs L10 life @ 33-1/3 RPM	Static Limit		
							Norm	Tol								
VLRY-2-1/2	90262	2.500	0.937	0.875	1.750	0.468	0.437		0.875	0.031	BB	710	1850	780	480	1.0
VLRY-3	90263	3.000	1.312	1.250	2.062	0.656	0.625		1.125	0.031	BB	1300	3400	1810	1120	2.1
VLRY-3-1/2-7	90109	3.500	1.562	1.500	2.250	0.781	0.750		1.250	0.031	BB	1560	4090	1810	1120	2.8
VLRY-3-3/4	96655	3.750	1.562	1.500	2.500	0.785	0.750		1.250	0.031	TRB	4570	10880	7630	4570	3.1
VLRY-4-1/2	96266	4.500	1.812	1.750	3.000	0.906	1.000		1.750	0.031	TRB	6000	14270	20000	12000	5.0
VLRY-5	96279	5.000	2.062	2.000	3.500	1.030	1.125		2.000	0.031	TRB	7390	17590	27200	13100	7.6
VLRY-5-1/2	96283	5.500	2.312	2.250	4.000	1.156	1.250		2.250	0.031	TRB	7390	17590	27200	13100	11.2
VLRY-6-1/2	96287	6.500	2.875	2.750	5.000	1.437	1.750	+0.0005 -0.0000	3.500	0.062	TRB	15060	35840	^46030	^23010	18.8
VLRY-7-1/2	96291	7.500	3.375	3.250	6.000	1.687	2.250		3.500	0.062	TRB	15060	35840	^53860	^26930	30.5
VLRY-8-1/2	96292	8.500	3.875	3.750	7.000	1.937	2.750		4.250	0.062	TRB	17830	42430	^61710	^30850	44.7
VLRY-9-1/2	96297	9.500	4.500	4.250	8.000	2.250	3.255		4.750	0.125	TRB	35250	*83890	^69540	^34770	64.2
VLRY-10-1/2	96300	10.500	5.000	4.750	9.000	2.500	3.755		5.500	0.125	TRB	56400	*134230	^77380	^38690	77.5
VLRY-11-1/2	96302	11.500	5.500	5.250	10.000	2.750	4.255	+0.001 -0.000	6.500	0.125	TRB	58080	*138240	^85220	^42610	112.2

^Surface strength of roller OD

*Exceeds surface strength of roller OD

Other sizes available upon request
 For HEAVY DUTY SHAFTS see pages 60-61
 Refer to INSTALLATION NOTES on pages 83-85
 LOAD CAPACITIES ARE BASED ON UNIFORM AND STEADY LOADING.

Load Runners

Heavy-Duty Concentric Shafts for Yoke Style Idler-Rollers - Inch Sizes

Shaft Style A includes jam nut and lock washer

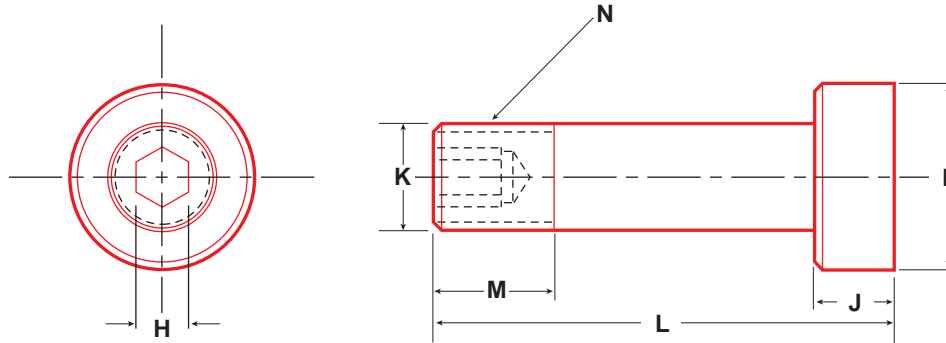

Part No.	Item No.	Fits PLRY & CLRY	Fits FLRY	Fits VLRV	E	H	J	K	L	M	N	Approx Weight (lbs)
					Head Dia	Hex Size	Head Length	Shaft Dia	Shaft Length	Thread Length	Thread	
					-0.0002 -0.0012			-0.0002 -0.0012				
SHA-437	90282	1-1/2	1/2	2-1/2	0.750	0.157	0.375	0.4375	2.062	0.625	7/16"-20	0.7
SHA-500	90283	1-3/4	1-3/4	-	0.875	0.250	0.437	0.500	2.375	0.750	1/2"-20	0.8
SHA-625	90284	2 & 2-1/4	2 & 2-1/4	3	1.125	0.312	0.500	0.625	3.000	0.875	5/8"-18	1.0
SHA-750	95006	2-1/2	2-1/2	3-1/2-7 +3-3/4	1.250	0.312	0.625	0.750	3.687	1.000	3/4"-16	1.2
SHA-1000	95008	3 & 3-1/4	3 & 3-1/4	4-1/2	1.750	0.500	0.750	1.000	4.312	1.125	1"-14	1.5
SHA-1125	95020	3-1/2	3-1/2	5	2.000	0.500	0.875	1.125	4.875	1.187	1-1/8"-12	2.1
SHA-1250	95023	4	4	5-1/2	2.250	0.500	0.875	1.250	5.250	1.312	1-1/4"-12	2.7
SHA-1750	95028	5	5	6-1/2	3.500	0.500	1.250	1.750	7.000	1.875	1-3/4"-12	8.3
SHA-2250	95036	6	6	7-1/2	3.500	0.625	1.250	2.250	7.750	2.125	2-1/4"-12	12.6
SHA-2750	95042	7	7	8-1/2	4.250	0.625	1.375	2.750	9.000	2.625	2-3/4"-12	22.3

Shaft Style B includes shaft retainers, socket head cap screws and lock washers

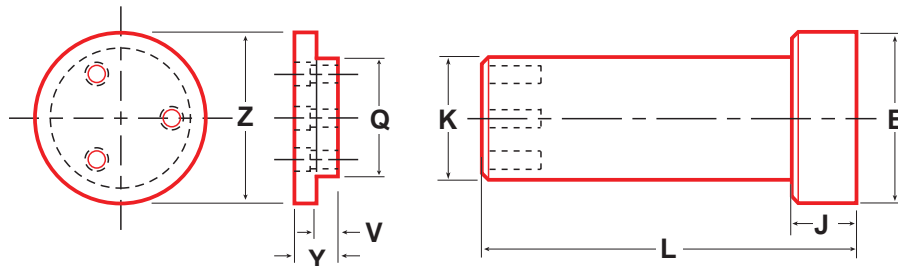

Part No.	Item No.	Fits FLRY	Fits PLRY	Fits VLRV	E	J	K	L	Q	V	Y	Z	Approx Weight (lbs)
					Head Dia	Head Length	Shaft Dia	Shaft Length	Retainer Mount Dia	Retainer Mount Length	Retainer Length	Retainer Dia	
					-0.0002 -0.0012		-0.0002 -0.0012						
SHB-3250	95045	8	8	9-1/2	4.750	1.875	3.254	7.625	3.250	0.500	1.000	4.000	25.3
SHB-3750	95049	9	9	10-1/2	5.500	2.125	3.754	8.625	3.750	0.500	1.125	4.500	38.3
SHB-4250	95050	10	10	11-1/2	6.500	2.250	4.254	9.375	4.250	0.500	1.125	5.000	54.6

Heavy-Duty Eccentric Shafts for Yoke Style Idler-Rollers - Inch Sizes

Shaft Style E includes flat washer, jam nut and lock washer

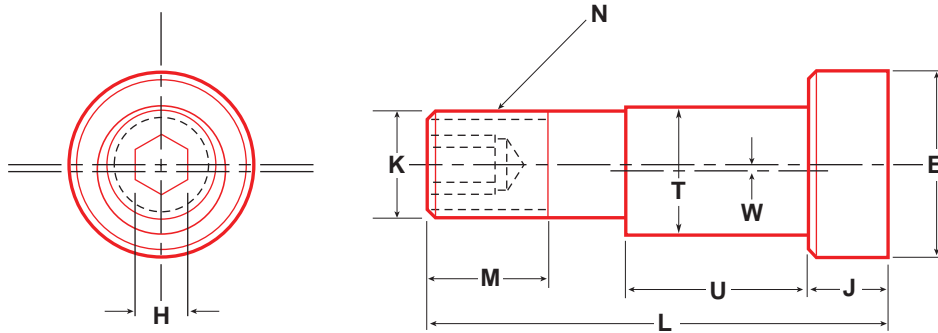

Part No.	Item No.	Fits PLRY & CLRY	Fits FLRY	Fits VLRY	Head Dia	Hex Size	Head Length	Shaft Dia	Shaft Length	Thread Length	Thread	Eccentric Dia	Eccentric Length	Eccentricity	Approx Weight (lbs)
					-0.0002 -0.0012			-0.0002 -0.0012				+0.001 -0.001	+0.000 -0.010		
SHE-437	90285	1-1/2	1-1/2	2-1/2	0.750	0.156	0.375	0.313	2.062	3/8	5/16-18	0.438	0.843	0.030	0.700
SHE-500	90286	1-3/4	1-3/4	-	0.875	0.156	0.437	0.375	2.375	9/16	3/8-24	0.500	0.968	0.030	1.000
SHE-625	90287	2 & 2-1/4	2 & 2-1/4	3	1.125	0.250	0.500	0.500	3.000	9/16	1/2-20	0.625	1.187	0.030	1.200
SHE-750	97507	2-1/2	2-1/2	3-1/2-7 +3-3/4	1.250	0.312	0.625	0.625	3.687	1	5/8-18	0.750	1.495	0.030	1.500
SHE-1000	95056	3 & 3-1/4	3 & 3-1/4	4-1/2	1.750	0.312	0.750	0.875	4.312	1-1/8	7/8-14	1.000	1.745	0.030	1.350
SHE-1125	95058	3-1/2	3-1/2	5	2.000	0.500	0.875	1.000	4.875	1-3/16	1-14	1.125	1.995	0.030	2.000
SHE-1250	95059	4	4	5-1/2	2.250	0.500	0.875	1.000	5.250	1-5/16	1-14	1.250	2.245	0.060	2.250
SHE-1750	96848	5	5	6-1/2	3.500	0.500	1.250	1.500	7.000	1-7/8	1-1/2-12	1.750	2.807	0.060	2.812
SHE-2250	97508	6	6	7-1/2	3.500	0.625	1.250	2.000	7.750	2-1/8	2-12	2.250	3.307	0.060	3.312
SHE-2750	97509	7	7	8-1/2	4.250	0.625	1.375	2.500	9.000	2-5/8	2-1/2-12	2.750	3.807	0.060	3.812

Load Runners

Plain - Concentric Stud Style - Metric Sizes (mm)

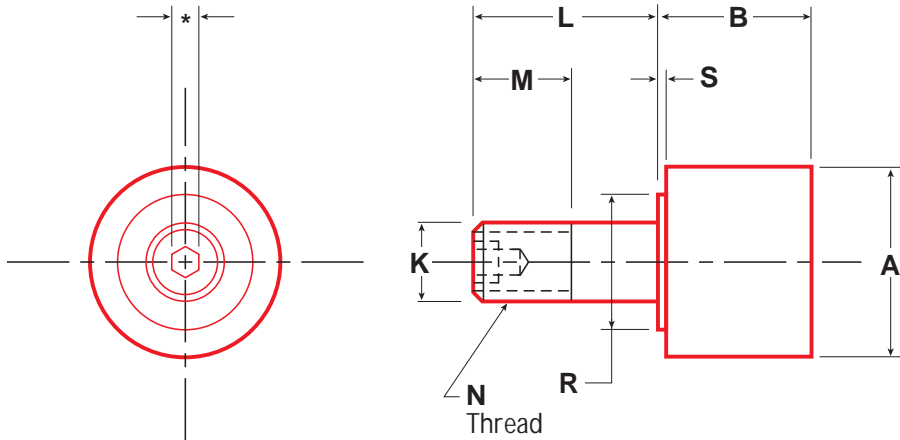

Part No.	Item No.	A	B	K	L	M	N	R	S	Rec. Mtg. Hole Size
		Roller Dia	Roller Width	Stud Dia	Stud Length	Thread Length	Thread	Shoulder Dia	Shoulder Length	
		+0.00 -0.02		+0.00 -0.02						
HPC-26	97374	26	20	10	23	13	M10×1	13.1	0.8	10.02
HPC-30	97375	30	20	12	25	14	M12×1.5	15.9	0.8	12.02
HPC-32	97376	32	22	12	25	14	M12×1.5	15.9	0.8	12.02
HPC-35	97377	35	22	16	32.5	18	M16×1.5	19.1	0.8	16.02
HPC-40	95064	40	30	14	40	26	M14×2	18	1.6	14.02
HPC-40-1	95063	40	27.6	18	36.5	19	M18×1.5	22	1.6	18.02
HPC-47	95065	47	27.6	20	40.5	21	M20×1.5	25.5	1.6	20.02
HPC-50	95068	50	40	16	50	35	M16×2	23	1.6	16.02
HPC-52	95066	52	33.6	20	40.5	21	M20×1.5	25.5	1.6	20.02
HPC-62	95070	62	44	24	58	35	M24×3	32	1.6	24.02
HPC-62-1	95069	62	44	24	49.5	25	M24×1.5	32	1.6	24.02
HPC-72	95072	72	44	24	49.5	25	M24×1.5	32	1.6	24.02
HPC-76	95074	76	52	30	69.5	40	M30×3.5	44.5	1.6	30.02
HPC-80	95075	80	52	30	69.5	40	M30×3.5	44.5	1.6	30.02
HPC-85	95076	85	52	30	69.5	40	M30×3.5	44.5	1.6	30.02
HPC-90	95077	90	52	30	69.5	40	M30×3.5	44.5	1.6	30.02
HPC-100	95079	100	52	30	80	50	M30×3.5	44.5	1.6	30.02
HPC-100-1	95078	100	52	30	69.5	40	M30×3.5	44.5	1.6	30.02
HPC-125	95080	125	76	48	105	60	M48×5	82.5	1.6	48.02
HPC-150	95081	150	76	64	140	82	M64×6	82.5	1.6	64.02
HPC-200	95082	200	76	64	140	82	M64×6	82.5	1.6	64.02

**Lock washer and jam nut available at additional cost For size see "N" dimension.
Other sizes available upon request

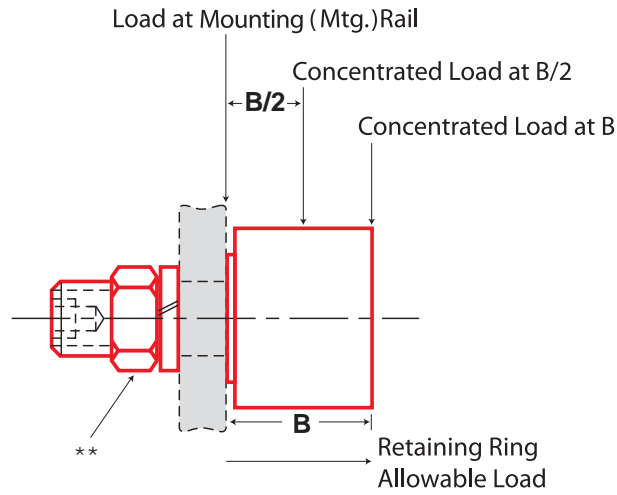

	Ball or Tapered Roller Bearings	Bearing Capacity Radial Load (N)			Bearing Capacity, Static Thrust (N)	Stud Capacity (lbs)			Retaining Ring Capacity (N)	Approx Weight (kg)	Part No.
		3000 hrs L10 life @ 100 RPM	500 hrs L10 life @ 33 1/3 RPM	Static Limit		Bending=0.75 Sy		Shear=0.75 x 0.5 x Sy			
						Bend @ B/2	Bend @ B				
BB	1070	2790	1000	620	2120	910	8780	1700	-	HPC-26	
BB	1070	2790	1000	620	2120	910	8780	1700	0.11	HPC-30	
BB	2300	6010	2690	1660	3820	1690	14450	2090	0.14	HPC-32	
BB	2300	6010	2690	1660	3790	1690	14450	2090	0.17	HPC-35	
BB	4680	12260	4900	3030	6170	2890	25690	2090	0.27	HPC-40	
BB	4680	12260	4900	3030	6330	3060	25690	2090	0.24	HPC-40-1	
BB	4680	12260	4900	3030	6330	3060	25690	2090	0.42	HPC-47	
BB	6490	17020	7210	4450	8810	4570	45760	4050	0.54	HPC-50	
BB	6490	17020	7210	4450	14430	7030	51600	4050	0.54	HPC-52	
BB	8810	23080	10090	6230	16090	7650	64850	5960	1.04	HPC-62	
BB	8810	23080	10090	6230	16070	7650	64850	5960	1.04	HPC-62-1	
TRB	20330	48390	33940	20330	26410	13840	102960	N/A	1.4	HPC-72	
TRB	26670	63480	88960	53380	45000	23170	160800	N/A	1.91	HPC-76	
TRB	26670	63480	88960	53380	45000	23170	160800	N/A	2.07	HPC-80	
TRB	26670	63480	88960	53380	45000	23170	160800	N/A	2.37	HPC-85	
TRB	26670	63480	88960	53380	45000	23170	160800	N/A	2.65	HPC-90	
TRB	26670	63480	88960	53380	45000	23170	160800	N/A	3.33	HPC-100	
TRB	26670	63480	88960	53380	45000	23170	160800	N/A	3.15	HPC-100-1	
TRB	62210	148070	230860	144570	128100	65120	411830	N/A	8.48	HPC-125	
TRB	66990	159430	250880	147240	301500	153930	731550	N/A	12.5	HPC-150	
TRB	66990	159430	250880	147240	301500	153930	731550	N/A	21.87	HPC-200	

LOAD CAPACITIES ARE BASED ON UNIFORM AND STEADY LOADING.

Load Runners

Plain - Eccentric Stud Style - Metric Sizes (mm)

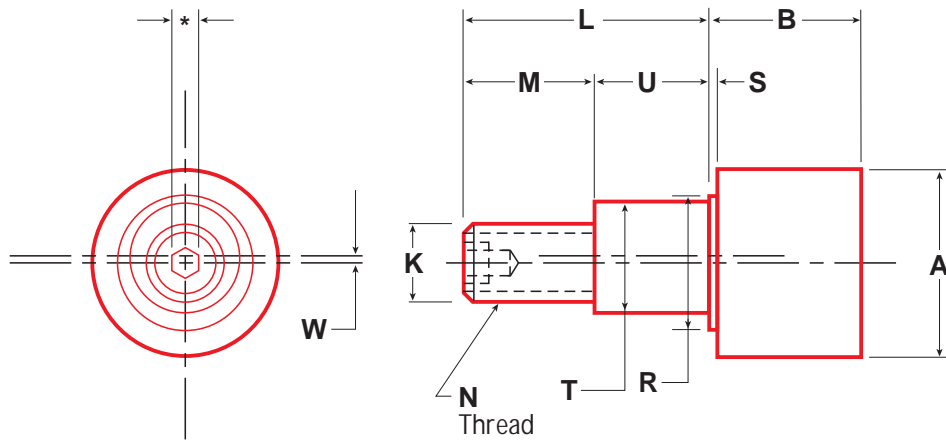

Part No.	Item No.	A	B	K	L	M	N	R	S	T	U	W	Rec. Mtg. Hole Size
		Roller Dia	Roller Width	Stud Dia	Stud Length	Thread Length	Thread	Shoulder Dia	Shoulder Length	Eccentric Dia	Eccentric Length	Eccentricity	
		+0.00 -0.02								+0.00 -0.05	+0.00 -0.25		
HPCE-26	97378	26	20	10	23	13	M10×1	17.1	0.8	13	10	0.5	13.02
HPCE-30	97379	30	20	12	25	14	M12×1.5	17.5	0.8	15	11	0.5	15.02
HPCE-32	97380	32	22	12	25	14	M12×1.5	17.5	0.8	15	11	0.5	15.02
HPCE-35	97381	35	22	16	32.5	18	M16×1.5	23.8	0.8	20	14.5	1	20.02
HPCE-40-1	95833	40	27.6	18	36.5	20.5	M18×1.5	28.5	1.6	22	16	1	22.02
HPCE-47	95835	47	27.6	20	40.5	22.5	M20×1.5	32	1.6	24	18	1	24.02
HPCE-50	95837	50	40	16	50	32	M16×2	32	1.6	24	18	1	24.02
HPCE-52	95836	52	33.6	20	40.5	22.5	M20×1.5	32	1.6	24	18	1	24.02
HPCE-62	95839	62	44	24	58	38	M24×3	43	1.6	28	20	1.5	28.02
HPCE-62-1	95838	62	44	24	49.5	27.5	M24×1.5	43	1.6	28	22	1	28.02
HPCE-72	95840	72	44	20	49.5	27.5	M20×1.5	38	1.6	28	22	1	28.02
HPCE-76-1	95841	76	52	24	70	41	M24×1.5	50	1.6	35	29	1.5	35.02
HPCE-80	95843	80	52	24	70	41	M24×1.5	50	1.6	35	29	1.5	35.02
HPCE-85	95844	85	52	24	70	41	M24×1.5	50	1.6	35	29	1.5	35.02
HPCE-90	95845	90	52	24	70	41	M24×1.5	50	1.6	35	29	1.5	35.02
HPCE-100	95846	100	52	24	70	41	M24×1.5	50	1.6	35	29	1.5	35.02
HPCE-125	95847	125	76	48	105	55	M48×5	82.5	1.6	64	50	1.5	64.02
HPCE-150	95848	150	76	64	140	75	M64×6	82.5	1.6	80	65	1.5	80.02

**Flat washer, lock washer and jam nut available at additional cost. For size see "N" dimension.
Other sizes available upon request

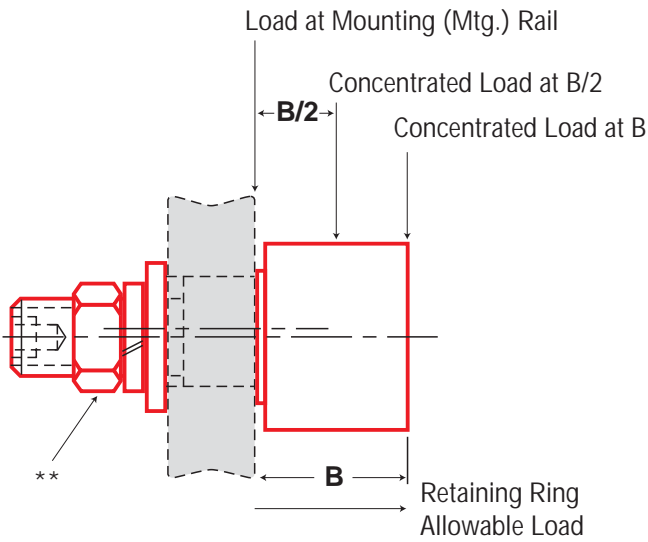

	Ball or Tapered Roller Bearings	Bearing Radial Load (N)			Bearing Capacity, Static Thrust (N)	Stud Capacity (lbs)			Retaining Ring Capacity (N)	Approx Weight (kg)	Part No.
		3000 hrs L10 life @ 100 RPM	500 hrs L10 life @ 33 1/3 RPM	Static Limit		Bending=0.75 Sy		Shear= 0.75 x 0.5 x Sy			
						Bend @ B/2	Bend @ B				
	BB	1070	2790	1000	620	2120	910	8780	1700	0.11	HPCE-26
	BB	1070	2790	1000	620	2020	890	8780	1700	0.14	HPCE-30
	BB	2300	6010	2690	1660	3820	1690	14450	2090	0.17	HPCE-32
	BB	2300	6010	2690	1660	3790	1690	14450	2090	0.2	HPCE-35
	BB	4680	12260	4900	3030	6330	3060	25690	2090	0.29	HPCE-40-1
	BB	4680	12260	4900	3030	6330	3060	25690	2090	0.45	HPCE-47
	BB	6490	17020	7210	4450	17700	6930	51600	4050	0.69	HPCE-50
	BB	6490	17020	7210	4450	14420	7030	51600	4050	0.72	HPCE-52
	BB	8810	23080	10090	6230	16070	7030	64850	5960	1.10	HPCE-62
	BB	8810	23080	10090	6230	16070	7650	64850	5960	1.08	HPCE-62-1
	TRB	20330	48390	33940	20330	15710	7650	71590	N/A	1.60	HPCE-72
	TRB	26670	63480	88960	53380	22980	8130	102740	N/A	1.99	HPCE-76-1
	TRB	26670	63480	88960	53380	22980	11830	102740	N/A	2.39	HPCE-80
	TRB	26670	63480	88960	53380	22980	11830	102740	N/A	2.54	HPCE-85
	TRB	26670	63480	88960	53380	22980	11830	102740	N/A	2.98	HPCE-90
	TRB	26670	63480	88960	53380	22980	11830	102740	N/A	3.29	HPCE-100
	TRB	62210	148070	230860	144570	128100	65120	411830	N/A	4.63	HPCE-125
	TRB	66990	159430	250880	147240	301500	159930	731550	N/A	5.56	HPCE-150

LOAD CAPACITIES ARE BASED ON UNIFORM AND STEADY LOADING.

Load Runners

Flanged - Concentric Stud Style - Metric Sizes (mm)

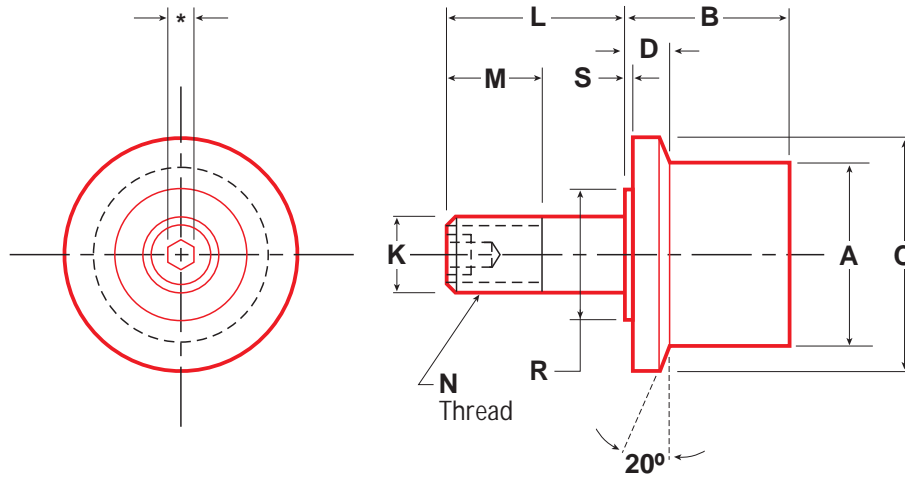

Part No.	Item No.	A	B	C	D	K	L	M	N	R	S	Rec. Mtg. Hole Size
		Roller Dia	Roller Width	Flange Dia	Flange Thickness	Stud Dia +0.00 -0.02	Stud Length	Thread Length	Thread	Shoulder Dia	Shoulder Length	
HPJ-26	97382	26	20	35	5	10	23	13	M10×1	13.1	0.8	10.02
HPJ-30	97383	30	20	40	5	12	25	14	M12×1.5	15.9	0.8	12.02
HPJ-32	97384	32	22	42	5	12	25	14	M12×1.5	15.9	0.8	12.02
HPJ-35	97385	35	22	46	5	16	32.5	18	M16×1.5	19.1	0.8	16.02
HPJ-40	95410	40	30	54	8.8	14	40	26	M14×2	18	1.6	14.02
HPJ-40-1	95409	40	27.6	54	7.8	18	36.5	19	M18×1.5	22	1.6	18.02
HPJ-47	95411	47	27.6	61	7.8	20	40.5	21	M20×1.5	25.5	1.6	20.02
HPJ-50	95415	50	40	68	14	16	50	35	M16×2	23	1.6	16.02
HPJ-52	95413	52	33.6	66	10.8	20	40.5	21	M20×1.5	25.5	1.6	20.02
HPJ-62	95420	62	44	78	14	24	58	35	M24×3	32	1.6	24.02
HPJ-62-2	95418	62	44	78	14	24	49.5	25	M24×1.5	32	1.6	24.02
HPJ-72	95422	72	44	90	14	24	49.5	25	M24×1.5	32	1.6	24.02
HPJ-76	95427	76	52	98	14	30	69.5	40	M30×3.5	44.5	1.6	30.02
HPJ-80	95429	80	52	102	14	30	69.5	40	M30×3.5	44.5	1.6	30.02
HPJ-85	95430	85	52	107	14	30	69.5	40	M30×3.5	44.5	1.6	30.02
HPJ-90	95431	90	52	112	14	30	69.5	40	M30×3.5	44.5	1.6	30.02
HPJ-100	95435	100	52	125	14	30	80	50	M30×3.5	44.5	1.6	30.02
HPJ-100-1	95434	100	52	125	14	30	69.5	40	M30×3.5	44.5	1.6	30.02
HPJ-125	95440	125	76	148	18	48	105	60	M48×5	82.5	1.6	48.02
HPJ-150	95441	150	76	173	18.3	64	140	82	M64×6	82.5	1.6	64.02
HPJ-200	95443	200	76	223	18.3	64	140	82	M64×6	82.5	1.6	64.02

**Lock washer and jam nut available at additional cost. For size see "N" dimension.
Other sizes available upon request.

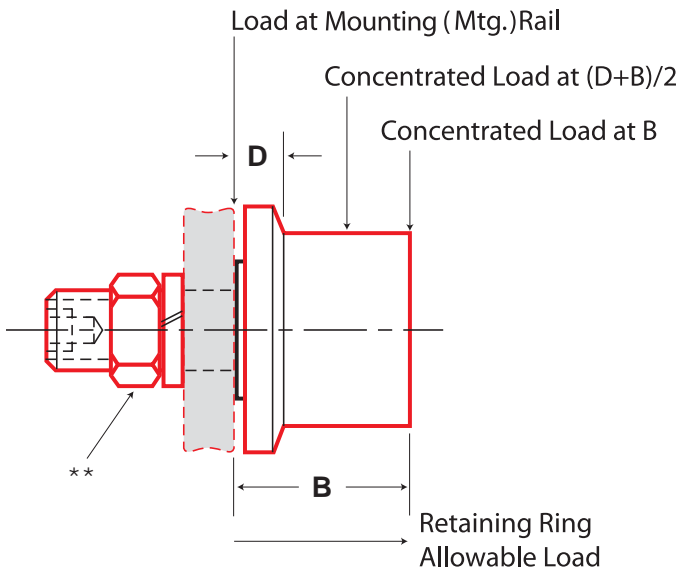

	Ball or Tapered Roller Bearings	Bearing Radial Capacity (N)			Bearing Capacity, Static Thrust (N)	Stud Capacity (lbs)			Retaining Ring Capacity (N)	Approx Weight (kg)	Part No.
		3000 hrs L10 life @ 100 RPM	500 hrs L10 life @ 33 1/3 RPM	Static Limit		Bending=0.75 Sy		Shear=0.75 x 0.5 x Sy			
						Bend @ (D+B)/2	Bend @ B				
BB	1070	2790	1000	620	1630	910	8780	1700	0.11	HPJ-26	
BB	1070	2790	1000	620	1680	910	8780	1700	0.14	HPJ-30	
BB	2300	6010	2690	1660	3140	1690	14450	2090	0.17	HPJ-32	
BB	2300	6010	2690	1660	3120	1690	14450	2090	0.2	HPJ-35	
BB	4680	12260	4900	3030	4890	2890	25690	2090	0.33	HPJ-40	
BB	4680	12260	4900	3030	5040	3060	25690	2090	0.24	HPJ-40-1	
BB	4680	12260	4900	3030	5040	3060	25690	2090	0.47	HPJ-47	
BB	6490	17020	7210	4450	6860	4570	45760	4050	0.7	HPJ-50	
BB	6490	17020	7210	4450	11080	7030	51600	4050	0.83	HPJ-52	
BB	8810	23080	10090	6230	12340	7650	64850	5960	1.21	HPJ-62	
BB	8810	23080	10090	6230	12340	7650	64850	5960	1.21	HPJ-62-2	
TRB	20330	48390	33940	20330	21390	14030	102960	N/A	1.28	HPJ-72	
TRB	26670	63480	88960	53380	36890	23150	160800	N/A	2.17	HPJ-76	
TRB	26670	63480	88960	53380	36890	23150	160800	N/A	2.41	HPJ-80	
TRB	26670	63480	88960	53380	36890	23150	160800	N/A	2.75	HPJ-85	
TRB	26670	63480	88960	53380	36890	23150	160800	N/A	2.98	HPJ-90	
TRB	26670	63480	88960	53380	36890	23150	160800	N/A	3.7	HPJ-100	
TRB	26700	63480	88960	53380	36890	23150	160800	N/A	3.52	HPJ-100-1	
TRB	62210	148070	230860	144570	106160	64910	411830	N/A	8.86	HPJ-125	
TRB	66990	159430	250880	147240	254530	153930	731550	N/A	13.07	HPJ-150	
TRB	66990	159430	250880	147240	254530	153930	731550	N/A	20.37	HPJ-200	

LOAD CAPACITIES ARE BASED ON UNIFORM AND STEADY LOADING.

Load Runners

Flanged - Eccentric Stud Style - Metric Sizes (mm)

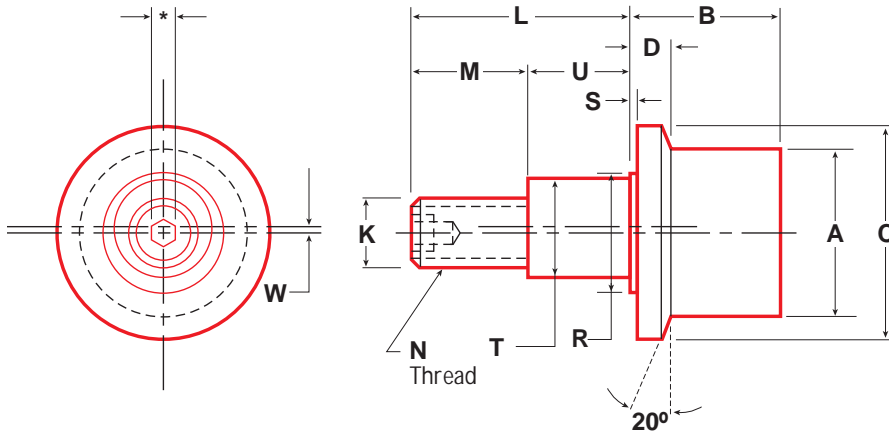

Part No.	Item No.	A	B	C	D	K	L	M	N	R	S	T	U	W	Rec. Mtg. Hole Size
		Roller Dia	Roller Width	Flange Dia	Flange Thickness	Stud Dia	Stud Length	Thread Length	Thread	Shldr Dia	Shldr Length	Eccentric Dia	Eccentric Length	Eccentricity	
HPJE-26	97386	26	20	35	5	10	23	13	M10×1	17.1	0.8	13	10	0.5	13.02
HPJE-30	97387	30	20	40	5	12	25	14	M12×1.5	17.5	0.8	15	11	0.5	15.02
HPJE-32	97388	32	22	42	5	12	25	14	M12×1.5	17.5	0.8	15	11	0.5	15.02
HPJE-35	97389	35	22	46	5	16	32.5	18	M16×1.5	23.8	0.8	20	14.5	1	20.02
HPJE-40-1	95907	40	27.6	54	7.8	18	36.5	20.5	M18×1.5	28.5	1.6	22	16	1	22.02
HPJE-50	95909	50	40	68	14	16	50	32	M16×2	32	1.6	24	18	1	24.02
HPJE-62-1	95910	62	44	78	14	24	49.5	27.5	M24×1.5	43	1.6	28	22	1	28.02
HPJE-76	95912	76	52	98	14	24	70	41	M24×1.5	50	1.6	35	29	1.5	35.02
HPJE-90	95913	90	52	112	14	24	70	41	M24×1.5	50	1.6	35	29	1.5	35.02
HPJE-100	95914	100	52	125	14	24	70	41	M24×1.5	50	1.6	35	29	1.5	35.02
HPJE-125	95915	125	76	148	18	48	105	55	M48×5	82.5	1.6	64	50	1.5	64.02
HPJE-150	95916	150	76	173	18.3	64	140	75	M64×6	92	1.6	80	65	1.5	80.02

**Flat washer, lock washer and jam nut available at additional cost. For size see "N" dimension.
Other sizes available upon request.

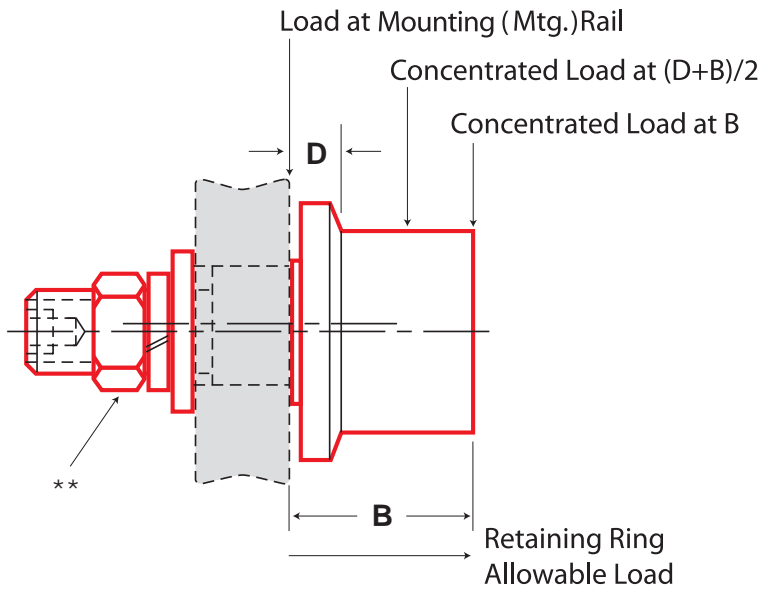

	Ball or Tapered Roller Bearings	Bearing Radial Load (N)			Bearing Capacity, Static Thrust (N)	Stud Capacity (lbs)			Retaining Ring Capacity (N)	Approx Weight (kg)	Part No.
		3000 hrs L10 life @ 100 RPM	500 hrs L10 life @ 33 1/3 RPM	Static Limit		Bending=0.75 Sy		Shear= 0.75 x 0.5 x Sy			
						Bend @ (D+B)/2	Bend @ B				
	BB	1070	2790	1000	620	1610	890	8780	1700	0.14	HPJE-26
	BB	1070	2790	1000	620	1610	890	8780	1700	0.17	HPJE-30
	BB	2300	6010	2690	1660	3070	1690	14450	2090	0.2	HPJE-32
	BB	2300	6010	2690	1660	3130	1690	14450	2090	0.23	HPJE-35
	BB	4680	12260	4900	3030	5040	3060	25690	2090	0.35	HPJE-40-1
	BB	6490	17020	7210	4450	11980	6930	51600	4050	0.94	HPJE-50
	BB	8810	23080	10090	6230	12340	7650	64850	5960	1.13	HPJE-62-1
	TRB	26670	63480	88960	53380	18840	11820	102740	N/A	2.31	HPJE-76
	TRB	26670	63480	88960	53380	18840	11820	102740	N/A	3.09	HPJE-90
	TRB	26670	63480	88960	53380	18840	11820	102740	N/A	3.79	HPJE-100
	TRB	62210	148070	230860	144570	106160	65120	411830	N/A	4.74	HPJE-125
	TRB	66990	159430	250880	147240	254530	153930	731550	N/A	5.69	HPJE-150

LOAD CAPACITIES ARE BASED ON UNIFORM AND STEADY LOADING.

Load Runners

V-Grooved - Concentric Stud Style - Metric Sizes (mm)

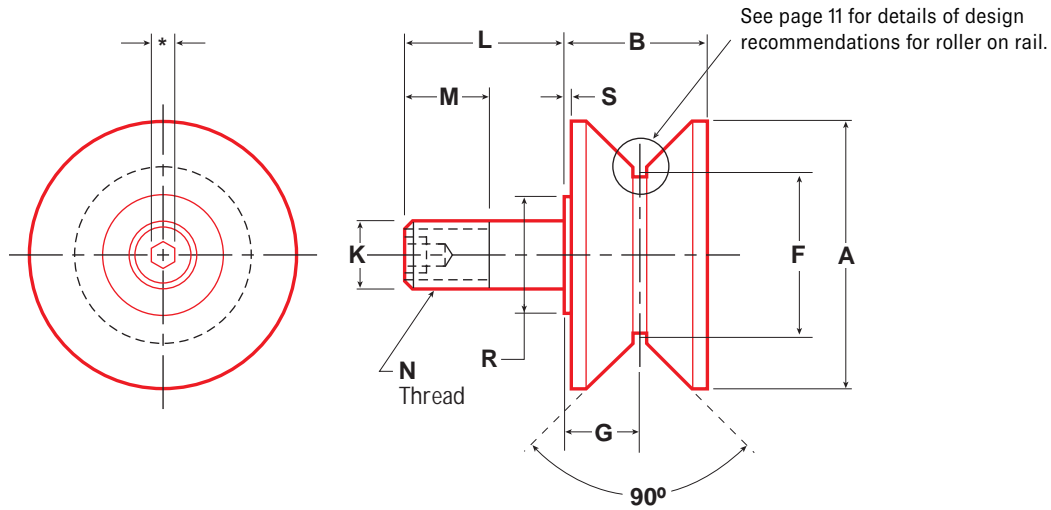

Part No.	Item No.	A	B	F	G	K	L	M	N	R	S	Rec. Mtg. Hole Size
		Roller Dia	Roller Width	Point Dia	Groove Location	Stud Dia +0.00 -0.02	Stud Length	Thread Length	Thread	Shoulder Dia	Shoulder Length	
HPV-26	97390	40	20	26	10	10	23	13	M10×1	13.1	0.5	10.02
HPV-32	97391	50	22	32	11	12	25	14	M12×1.5	15.9	0.8	12.02
HPV-40	95648	60	33	40	17	14	40	26	M14×2	18	1.6	14.02
HPV-62	95652	90	44.5	62	23	24	57.9	34.9	M24×3	32	1.6	24.02
HPV-62-1	95651	90	44.5	62	23	24	49.5	25	M24×1.5	32	1.6	24.02
HPV-76	95654	120	50.5	76	26	30	70	40	M30×3.5	44.5	1.6	30.02
HPV-100	95656	140	50.5	100	26	30	80	50	M30×3.5	44.5	1.6	30.02
HPV-100-1	95655	140	50.5	100	26	30	69.5	40	M30×3.5	44.5	1.6	30.02
HPV-125	95657	165	76	125	37.8	48	105	60	M48×5	82.5	1.6	48.02

**Lock washer and jam nut available at additional cost. For size see "N" dimension.
Other sizes available upon request.

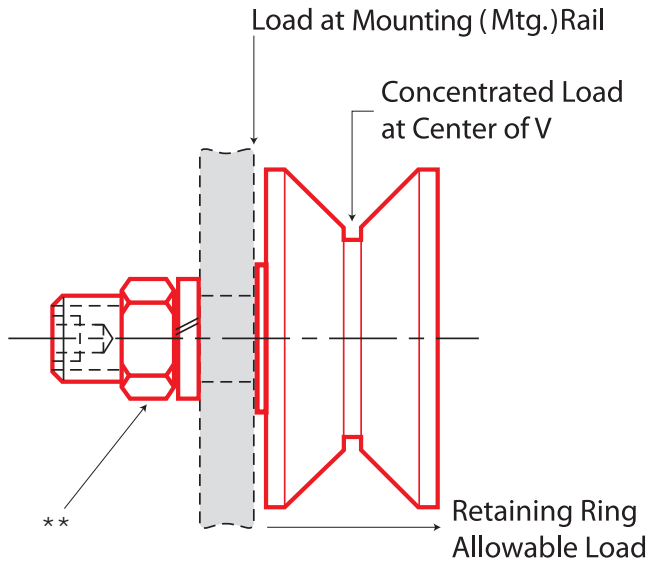

	Ball or Tapered Roller Bearings	Bearing Radial Capacity (N)			Bearing Capacity, Static Thrust (N)	Stud Capacity (N)		Retaining Ring Capacity (N)	Approx Weight (kg)	Part No.
		3000 hrs L10 life @ 100 RPM	500 hrs L10 life @ 33 1/3 RPM	Static Limit		Bending = 0.75Sy Bend @V	Shear = 0.75 x 0.5 x Sy Load @ Mtg Rail			
	BB	1070	2790	1000	620	2210	8780	1700	0.23	HPV-26
	BB	2300	6010	2690	1660	3960	14450	2090	0.26	HPV-32
	BB	4680	12260	4900	3030	5480	25690	2090	0.53	HPV-40
	BB	8810	23080	10090	6230	15960	64850	5960	1.79	HPV-62
	BB	8810	23080	10090	6230	15880	64850	5960	1.9	HPV-62-1
	TRB	26670	63480	88960	53380	46360	160800	N/A	3.27	HPV-76
	TRB	26670	63480	88960	53380	46270	160800	N/A	4.77	HPV-100
	TRB	26670	63480	88960	53380	46270	160800	N/A	4.77	HPV-100-1
	TRB	62210	148070	^216290	^108140	130771	411830	N/A	11.56	HPV-125

^Surface strength of roller OD

LOAD CAPACITIES ARE BASED ON UNIFORM AND STEADY LOADING.

Load Runners

V-Grooved - Eccentric Stud Style - Metric Sizes (mm)

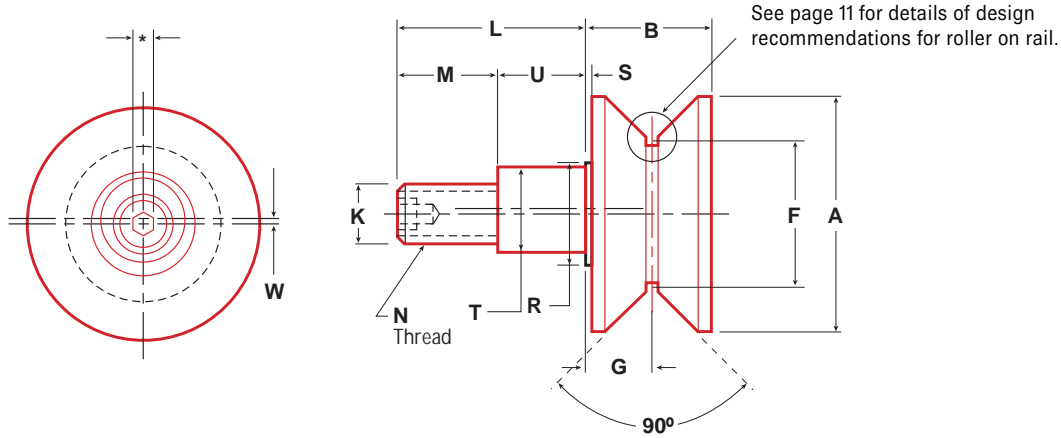

Part No.	Item No.	A	B	F	G	K	L	M	N	R	S	T	U	W	Rec. Mtg. Hole Size
		Roller Dia	Roller Width	Point Dia	Groove Location	Stud Dia	Stud Length	Thread Length	Thread	Shldr Dia	Shldr Length	Eccentric Dia +0.00 -0.05	Eccentric Length +0.00 -0.25	Eccentricity	
HPVE-26	97392	40	20	26	10	10	23	13	M10x1	17.1	0.6	13.00	10	0.5	13.02
HPVE-32	97393	50	22	32	11	12	25	14	M12x1.5	17.5	0.8	15.00	11	0.5	15.02
HPVE-40	95951	60	33	40	17	14	40	24	M14x2	28.5	1.6	22	16	1	22.02
HPVE-62	95953	90	44.5	62	23	24	58	38	M24x3	43	1.6	28	20	1.5	28.02
HPVE-62-1	95952	90	44.5	62	23	24	49.5	27.5	M24x1.5	43	1.6	28	22	1	28.02
HPVE-76	95955	120	50.5	76	26	24	70	41	M24x1.5	50	1.6	35	29	1.5	35.02
HPVE-100	95956	140	50.5	100	26	24	70	41	M24x1.5	50	1.6	35	29	1.5	35.02
HPVE-125	95957	165	76	125	37.8	48	105	55	M48x5	82.5	1.6	64	50	1.5	64.02

**Lock washer and jam nut available at additional cost. For size see "N" dimension.
 For stud socket size, see page 85.
 Other sizes available upon request

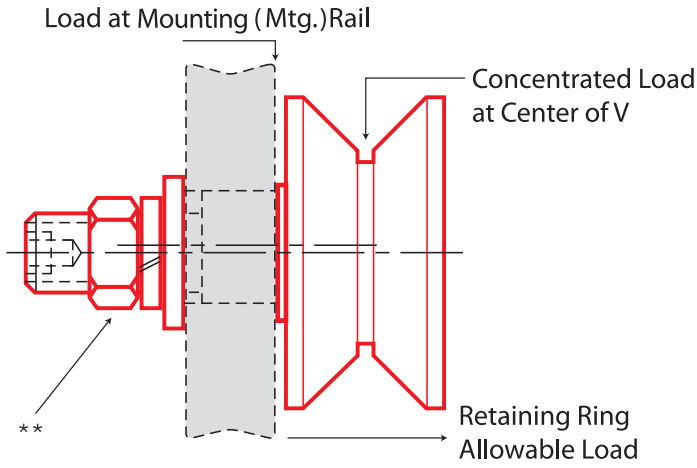

	Ball or Tapered Roller Bearings	Bearing Radial Load (N)			Bearing Capacity, Static Thrust (N)	Stud Capacity (N)		Retaining Ring Capacity (N)	Approx Weight (kg)	Part No.
		3000 hrs L10 life @ 100 RPM	500 hrs L10 life @ 33 1/3 RPM	Static Limit		Bending = 0.75Sy Bend @V	Shear = 0.75 x 0.5 x Sy Load @ Mtg Rail			
	BB	1070	2790	1000	620	2220	8780	1700	0.26	HPVE-26
	BB	2300	6010	2690	1660	3960	14450	2090	0.30	HPVE-32
	BB	4680	12260	4900	3030	5480	25690	2090	0.64	HPVE-40
	BB	8810	23080	10090	6230	15800	64850	5960	1.57	HPVE-62
	BB	8810	23080	10090	6230	15800	64850	5960	1.57	HPVE-62-1
	TRB	26670	63480	88960	53380	23520	113910	N/A	3.43	HPVE-76
	TRB	26670	63480	88960	53380	23630	113910	N/A	4	HPVE-100
	TRB	62210	148070	^216290	^108140	130770	411830	N/A	4.72	HPVE-125

^Surface strength of roller OD

LOAD CAPACITIES ARE BASED ON UNIFORM AND STEADY LOADING.

Load Runners

Plain - Yoke Style - Metric Sizes (mm)

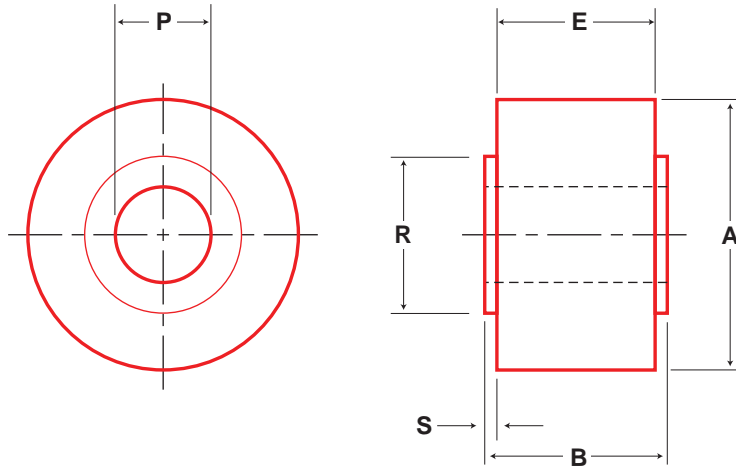

Part No.	Item No.	A		B		E		P		R		S		Ball or Tapered Roller Bearings	Bearing Radial Capacity (N)			Bearing Static Thrust Capacity (N)	Approx Weight (kg)
		Roller Dia	Roller Width	Tread Width	Bore	Shldr Dia	Shldr Length	3000 hrs L10 life @ 100 RPM	500 hrs L10 life @ 33 1/3 RPM	Static Limit									
		+0.00 -0.02			+0.00 -0.02														
HPCA-40	90271	40	23	22	10	22	0.5	BB	3140	8220	3460	2140	0.14						
HPCA-50	90272	50	33	32	15	28	0.5	BB	5780	15140	8070	4980	0.32						
HPCA-62	97297	62	40	38	20	32	1	TRB	20330	48390	33900	20300	0.91						
HPCA-62-2	90273	62	40	38	20	32	1	BB	9490	24880	11240	6940	0.91						
HPCA-76	96105	76	46	44	25	44.5	1	TRB	26670	63480	88960	53380	1.24						
HPCA-80	96107	80	46	44	25	44.5	1	TRB	26670	63480	88960	53380	1.41						
HPCA-85	96108	85	46	44	25	44.5	1	TRB	26670	63480	88960	53380	1.6						
HPCA-90	96109	90	56	54	30	57.2	1	TRB	32870	78240	120990	58270	1.92						
HPCA-100	96110	100	56	54	30	57.2	1	TRB	32870	78240	120990	58270	2.93						
HPCA-125	96111	125	71	68	45	82.6	1.5	TRB	62210	148070	230860	144570	5.01						
HPCA-150	96112	150	73	70	55	88.9	1.5	TRB	66990	159430	250880	147240	8.65						
HPCA-200	96114	200	79	76	70	108	1.5	TRB	79300	188740	354970	215290	19.58						
HPCA-250	96116	250	79	76	70	108	1.5	TRB	79300	188740	354970	215290	35.74						

For heavy duty shafts, see page 77
 Other sizes available upon request
 Refer to INSTALLATION NOTES on pages 83-85
 LOAD CAPACITIES ARE BASED ON UNIFORM AND STEADY LOADING.

Load Runners Flanged - Yoke Style - Metric Sizes (mm)

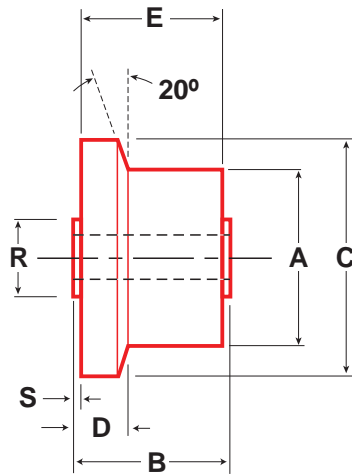
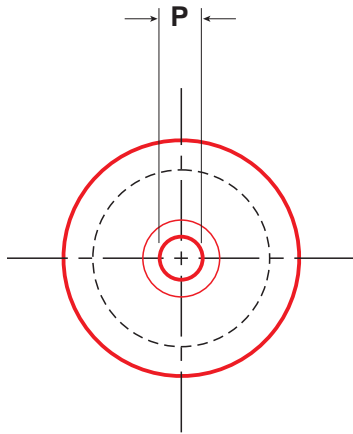

Part No.	Item No.	A	B	C	D	E	P	R	S	Ball or Tapered Roller Bearings	Bearing Radial Capacity (N)			Bearing Static Thrust Capacity (N)	Approx Weight (kg)
		Roller Dia	Roller Width	Flange Dia	Flange Thickness	Tread Width	Bore +0.00 -0.02	Shldr Dia	Shldr Length		3000 hrs L10 life @ 100 RPM	500 hrs L10 life @ 33 1/3 RPM	Static Limit		
HPJA-40	90274	40	23	54	6.0	22	10	22.0	0.5	BB	3140	8220	3460	2140	0.19
HPJA-50	90275	50	33	68	10.0	32	15	28.0	0.5	BB	5780	15140	8070	4980	0.64
HPJA-62	97298	62	40	78	14.0	38	20	32.0	1.0	TRB	20330	48390	33940	20330	1.09
HPJA-62-2	90276	62	40	78	14.0	38	20	32.0	1.0	BB	9490	24880	11240	6940	1.09
HPJA-76	96209	76	46	98	13.5	44	25	44.5	1.0	TRB	26670	63480	88960	53380	1.24
HPJA-80	96210	80	46	102	13.5	44	25	44.5	1.0	TRB	26670	63480	88960	53380	1.71
HPJA-85	96211	85	46	107	13.5	44	25	44.5	1.0	TRB	26670	63480	88960	53380	1.95
HPJA-90	96212	90	56	112	13.5	54	30	57.2	1.0	TRB	32870	78240	120990	58270	2.37
HPJA-100	96213	100	56	122	13.5	54	30	57.2	1.0	TRB	32870	78240	120990	58270	3.43
HPJA-125	96214	125	71	148	18.2	68	45	82.6	1.5	TRB	62210	148070	230860	144570	5.72
HPJA-150	96215	150	73	173	18.2	70	55	88.9	1.5	TRB	66990	159430	250880	147240	9.56
HPJA-200	96217	200	79	223	18.2	76	70	108.0	1.5	TRB	79300	188740	354970	215290	20.78
HPJA-250	96219	250	79	273	18.2	76	70	108.0	1.5	TRB	79300	188740	354970	215290	37.25

For heavy duty shafts, see page 77
 Other sizes available upon request
 Refer to INSTALLATION NOTES on pages 83-85
 LOAD CAPACITIES ARE BASED ON UNIFORM AND STEADY LOADING.

Load Runners

V-Grooved - Yoke Style - Metric Sizes (mm)

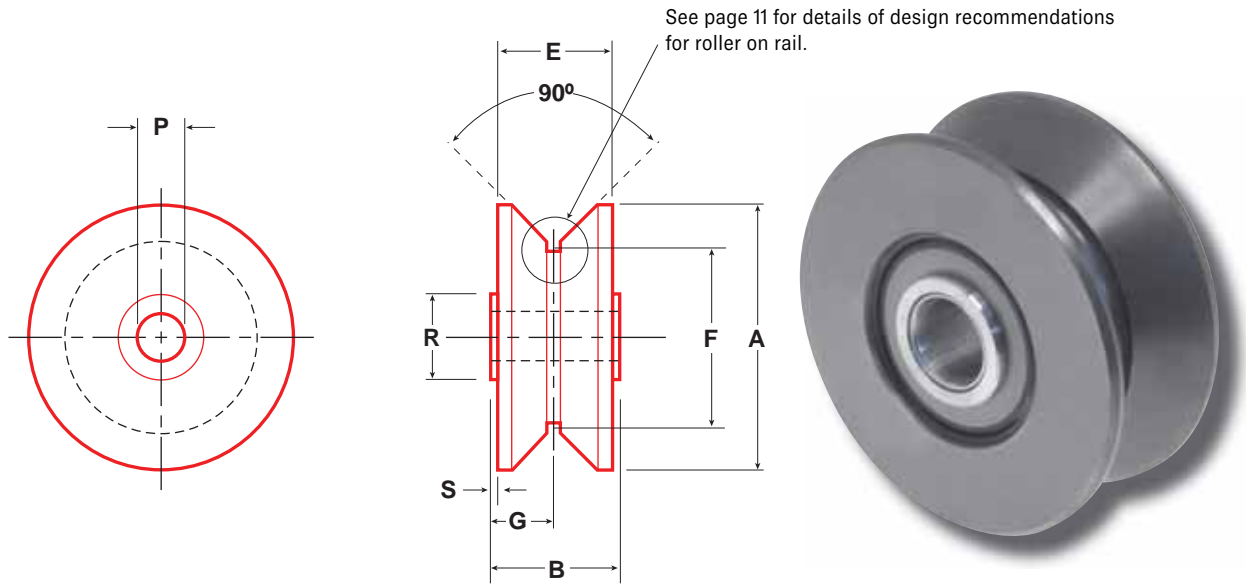

Part No.	Item No.	A	B	E	F	G	P	R	S	Ball or Tapered Roller Bearings	Bearing Radial Capacity (N)			Bearing Static Thrust Capacity (N)	Approx Weight (kg)
		Roller Dia	Roller Width	Tread Width	Point Dia	Groove Location	Bore +0.00 -0.02	Shldr Dia	Shldr Length		3000 hrs L10 life @ 100 RPM	500 hrs L10 life @ 33-1/3 RPM	Static Limit		
HPVA-40	90277	60	23	22	40	11.5	10	22.0	0.5	BB	3140	8220	3460	2140	0.460
HPVA-50	90278	75	33	32	50	16.5	15	28.0	0.5	BB	5780	15140	8070	4980	0.960
HPVA-62	97299	90	40	38	62	20.0	20	32.0	1.0	TRB	20300	48390	33940	20330	1.270
HPVA-62-2	90279	90	40	38	62	20.0	20	32.0	1.0	BB	6930	18170	10590	6540	1.270
HPVA-76	96255	110	46	44	76	23.0	25	44.5	1.0	TRB	26670	63480	88960	53380	2.210
HPVA-100	96256	140	56	54	100	28.0	30	57.2	1.0	TRB	32870	78240	120990	58270	5.080
HPVA-125	96257	165	71	68	125	35.5	45	82.6	1.5	TRB	62210	148070	[^] 216290	[^] 108140	8.520
HPVA-150	96259	190	73	70	150	36.5	55	88.9	1.5	TRB	66990	159430	250880	[^] 126380	13.79
HPVA-200	96261	240	79	76	200	39.5	70	108.0	1.5	TRB	79300	188740	[^] 325740	[^] 162870	29.60
HPVA-250	96263	290	79	76	250	39.5	70	108.0	1.5	TRB	79300	188740	354970	[^] 199360	56.52

[^]Surface strength of roller OD

*Exceeds surface strength of roller OD

For heavy duty shafts, see page 77

Other sizes available upon request

Refer to INSTALLATION NOTES on pages 83-85

LOAD CAPACITIES ARE BASED ON UNIFORM AND STEADY LOADING.

Load Runners

Heavy Duty Concentric Shafts for Yoke Style Idler-Rollers - Metric Sizes (mm)

Shaft Style A includes jam nut and lock washer

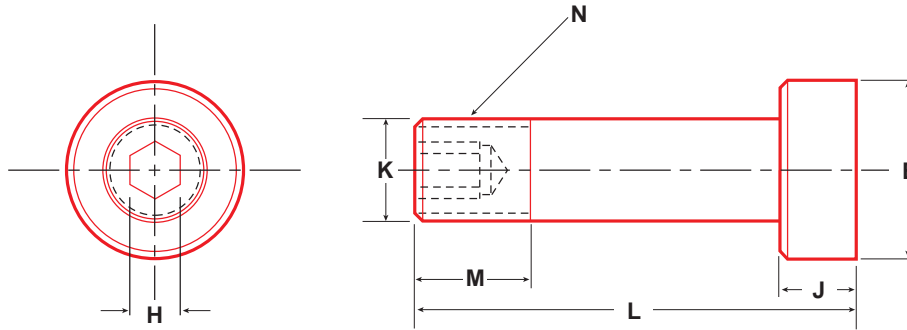

Part No.	Item No.	Fits HPCA & HPJA	Fits HPVA	E	H	J	K	L	M	N	Approx Weight (kg)
				Head Dia	Hex Size	Head Length	Shaft Dia				
				-0.025 -0.050			-0.025 -0.050				
MSHA-10	90280	40	40	18.00	4.0	10	10	55	15	M10×1.0	0.320
MSHA-15	90281	50	50	25.00	8.0	14	15	80	22	M14×2.0	0.460
MSHA-20	97300	62	62	31.75	8.0	16	20	94	25	M20×1.5	0.700
MSHA-25	95001	76, 80, 85	76	44.50	8.0	19	25	110	29	M24×1.5	0.750
MSHA-30	95002	90, 100	100	57.20	12.2	22	30	135	31	M30×3.5	0.950
MSHA-45	95003	125	125	82.60	12.2	32	45	185	54	M45×4.5	1.500
MSHA-55	95004	150	150	88.90	12.2	32	55	195	62	M52×5	5.700
MSHA-70	95005	200, 250	200, 250	108.00	12.2	35	70	220	74	M70×6	10.00

Load Runners CAM RUNNERS

Needle Bearing Alternative

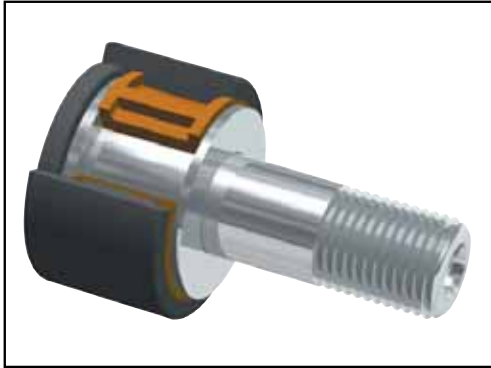

Osborn Cam Runners are significantly different from conventional needle bearing style cam followers.

General Characteristics:

Cam Runners are manufactured with a composite synthetic tread and stainless steel stud. The composite tread consists of two different synthetic materials chosen to provide optimal characteristics for the outer wear surface and the inner bearing surface. The two synthetic parts are molded together to form a single mechanically bonded assembly that is mounted on the stud, eliminating the need for conventional seals and lubricants. The outer tread material offers high mechanical strength while the inner bearing material provides high lubricity.

The stud provides optimum life and corrosion resistance. Tread bearing wear is critically dependent on the hardness of the mating surface. When this assembly is used as a direct replacement for a conventional cam follower, the life will be optimized if the cam or other mating surface is within the range of 55 - 60 Rc. Softer or harder materials may result in decreased life, particularly under high loads. The mating surface must be free of grease, oil and abrasive contaminants.

This assembly is dimensionally interchangeable with conventional steel cam followers. Because of its unique construction, comparable load ratings are not applicable. In order to guide you in choosing applications, extensive testing has been utilized to develop life expectancies based upon continuous duty testing at various speeds and loads. In continuous duty operation under identical loads and speeds, the Cam Runner has been found to outlast conventional steel cam followers by an average of 10 times!

Bearing to stud clearance is greater than for needle bearing designs and will increase during early use and will stabilize after "wearing in"

Advantages:

- No lubrication required – ever!
- Non sparking and low electrical conductivity
- Thrust load tolerant
- Extended life, ideal for difficult-to-service-operations
- No lubricant leakage to contaminate your process
- Quiet operation resulting from no internal moving parts
- Wide range of operating temperatures
- ISO 9001 compliant

Not recommended for ambient temperatures above 250° F, highly abrasive applications or repeated heavy shock loads.

Load Runners CAM RUNNERS Plain - Concentric Stud Style - Inch Sizes

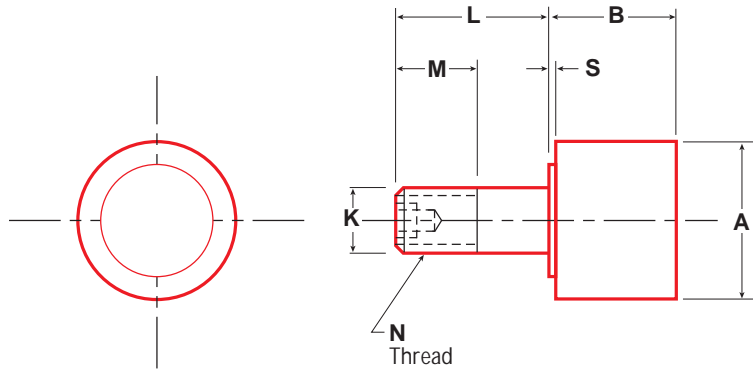

Part No.	Item No.	A	B	K	L	M	N	S	Radial Capacity Static Limit (lbs)	Approx Weight (lbs)
		Roller Dia	Roller Width	Stud Dia	Stud Length	Thread Length	Thread	Shoulder Length		
PCR-1/2	96959	0.500	0.406	0.188	0.625	0.250	10-32	0.031	110	0.05
PCR-9/16	96960	0.563	0.406	0.188	0.625	0.250	10-32	0.031	110	0.05
PCR-5/8	96961	0.625	0.469	0.250	0.750	0.313	1/4-28	0.031	230	0.05
PCR-11/16	96962	0.688	0.469	0.250	0.750	0.313	1/4-28	0.031	230	0.05
PCR-3/4	96963	0.750	0.563	0.375	0.875	0.375	3/8-24	0.063	700	0.10
PCR-7/8	96964	0.875	0.563	0.375	0.875	0.375	3/8-24	0.063	700	0.10
PCR-1	96965	1.000	0.688	0.438	1.000	0.500	7/16-20	0.063	870	0.10
PCR-1-1/8	96966	1.125	0.688	0.438	1.000	0.500	7/16-20	0.063	870	0.10
PCR-1-1/4	96967	1.250	0.813	0.500	1.250	0.625	1/2-20	0.063	1100	0.20
PCR-1-3/8	96968	1.375	0.813	0.500	1.250	0.625	1/2-20	0.063	1100	0.20
PCR-1-1/2	96969	1.500	0.938	0.625	1.500	0.750	5/8-18	0.063	1800	0.40
PCR-1-5/8	96970	1.625	0.938	0.625	1.500	0.750	5/8-18	0.063	1800	0.40

Cam Runners provided with hex jam nuts and lock washers.
LOAD CAPACITIES ARE BASED ON UNIFORM AND STEADY LOADING.

Load Runners
Technical Information / Special Order Form



Load Runners

Technical Information

Load Runners PART NUMBERING

Part Number	Description
PLR	Plain Load Runners
FLR	Flange Load Runners
VLR	V-Groove Load Runners
CLRY	Crowned Load Runners Yoke
SHA	Heavy-Duty Shaft
SHE	Heavy-Duty Eccentric Shaft
HPC	Metric Plain Load Runners
HPJ	Metric Flanged Load Runners
HPV	Metric V-Groove Load Runners
HPCA	Metric Plain Yoke
HPJA	Metric Flanged Yoke
HPVA	Metric V-Groove Yoke
PCR	Plain Cam Runners

Extensions	Description
PLR(E)	Eccentric Stud
FLR(C)	Crown Tread
(F)FLR	Double Flange
VLR(S)	Stainless Steel
PLR(N)	Nylon
FLR(Y)	Yoke
(H)PJ	Metric



Roll With The Best. Buy All Of Your Rail And Idler-Rollers From Osborn.

Contact us today and find out how Load Runners rail and idler rollers will remedy your unique material handling challenges. Our web site features in-depth information, CAD-drawings download, full catalog, installation instructions, and more.

Let the Osborn team help you determine the best solution for your needs.

Load Runners INSTALLATION NOTES

Tightening Torque

STUD DIAMETER	DRY THREADS	LUBRICATED THREADS
Less than 5/8" / 16mm	15 ft. lb. / 20 Nm	8 ft lb. / 10 Nm
5/8"/16 mm to 1"/24 mm	50 ft. lb. / 68 Nm	25 ft. lb. / 34 Nm
Over 1" / 24 mm	100 ft. lb. / 136 Nm	50 ft. lb. / 68 Nm

Osborn Load Runners Recommended Installation Procedure:

WARNING: High voltage and rotating parts may cause serious or fatal injury. Be sure to turn off power to machinery. Read and follow all instructions. Be sure to properly apply pressure when press-fitting your Load Runners. Hammering directly on the bearing could result in bearing damage or personal injury.

While lack of lubrication causes shorter operating life and product damage, Load Runners are designed and lubricated for life. In some instances, there is a convention to re-lubricate your Load Runners. Use the torque chart to install nuts properly. Do NOT over- or under-torque nuts.

Stud-Style Installation Considerations

1. Inspect the housing
 - a. Remove all burrs/sharp edges and clean.
 - b. Confirm housing bore diameter, insuring a snug fit with stud.
2. Install stud into housing
 - a. Do NOT hammer Load Runners at any time.
3. Install lock washer and jam nut
 - a. Do not tighten jam nut beyond torque specifications or damage may occur.
 - b. Use hexagonal hole (broach) with hex key to prevent the stud from rotating when the nut is tightened.

Blind Hole Mounting

Certain applications require blind hole mounting into tapped threads. Use the hex key to ensure adequate torque is applied.

Mounting Considerations

Mounting holes should be machined to the nominal stud size within $+.001/-0.000$ ($+.025$ mm/ $-.000$ mm) tolerance.

When properly aligned, the roller stud should slip into the mounting member. Do not force the stud into the mounting member as damage to the roller may occur.

When mounting rollers, do not torque the jam nuts beyond what is recommended or damage may occur. Be sure that the mounting member is of sufficient thickness to support the applied loads.

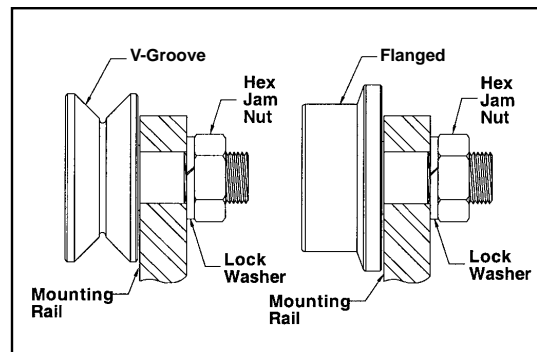

Installation NOTES

Yoke-Style Installation Considerations

Load Runners yoke-style idler-rollers offer considerable mounting flexibility. They can be installed on a bolt or thru-shaft between yoke brackets ("ears") which are fabricated as an integral part of the equipment, or in individual yoke brackets which can be bolted into position wherever needed.

It is important that the members which support the mounting bolt or thru-shaft are rigid enough to resist bending (which could cause uneven loading on the rollers) and strong enough to withstand the operational radial and thrust loads.

Osborn offers an exclusive line of heavy-duty thru-shafts designed specifically for use with yoke-style Load Runners idler-rollers. See pages 60, 61, and 77.

Axial clamping of yoke-style rollers (through the bore) is required to prevent the bearing components from separating, causing loss of bearing adjustment and premature failure. The outboard end of the mounting bolt or thru-shaft should be allowed to float in the yoke ear to avoid "pinching" and restricting the idler-roller tread when the roller is clamped. (See drawings below).

Shaft Style A

See pages 60 & 77 for actual shaft dimensions.

For Roller Sizes: PLRY + FLRY 1 1/2" Thru 7",
VLRY 2 1/2" Thru 8 1/2"
and all metrics

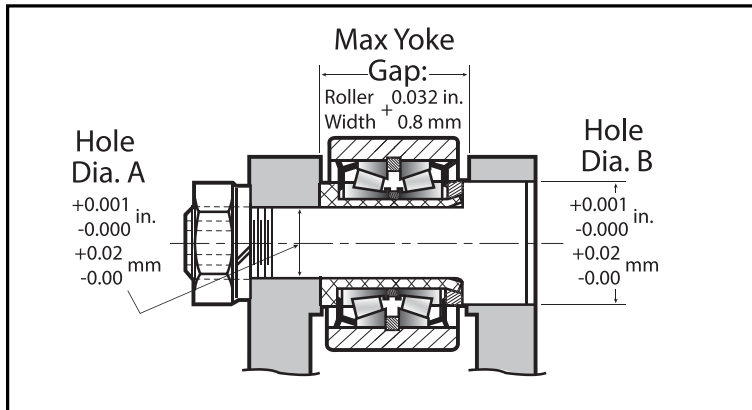

Shaft Style B

See page 60 for actual shaft dimensions.

For Roller Sizes: PLRY + FLRY 8" Thru 10",
VLRY 9 1/2" Thru 11 1/2"

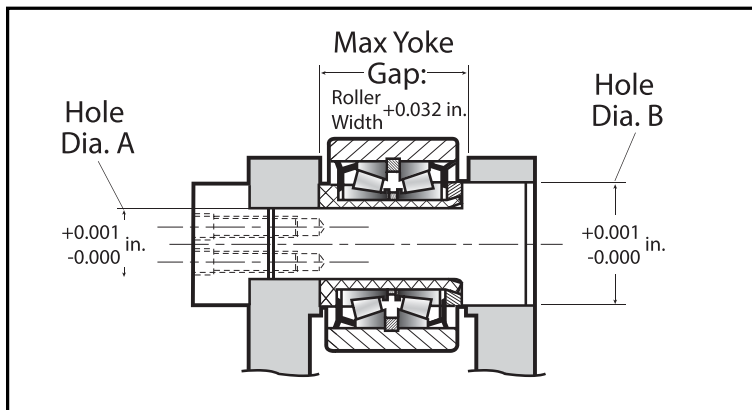

Flange Alignment

The shoulder on the flange end of a flanged yoke-style idler-roller serves as the dimensional reference point for accurate positioning of the roller flange with respect to the supported structure.

Orient each roller so that the flange is closest to the fixed (small diameter) end of the bolt or thru-shaft. (See Drawing.) When the bolt or thru-shaft is clamped, the reference shoulder will be pulled up tightly against the structure reference surface.

By mounting a string of flanged yoke-style rollers in this manner, all flanges will be properly aligned.

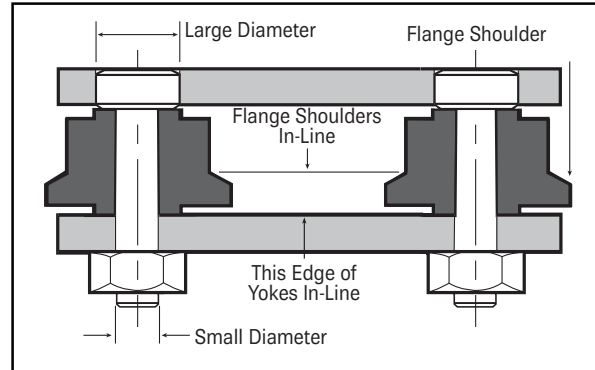

V-Grooved Alignment

The sharp-radius corner of a V-Grooved, yoke-style idler-roller indicates which shoulder should be used as a dimensional reference point for accurate alignment of a V-Grooved roller with respect to the supported structure.

Orient each roller so that the sharp-radius corner is closest to the fixed (small diameter) end of the bolt or thru-shaft. (See Drawing.) When the bolt or thru-shaft is clamped, the reference shoulder will be pulled up tightly against the structure reference surface.

By mounting a string of V-Grooved yoke-style rollers in this manner, all V-Grooves will be properly aligned.

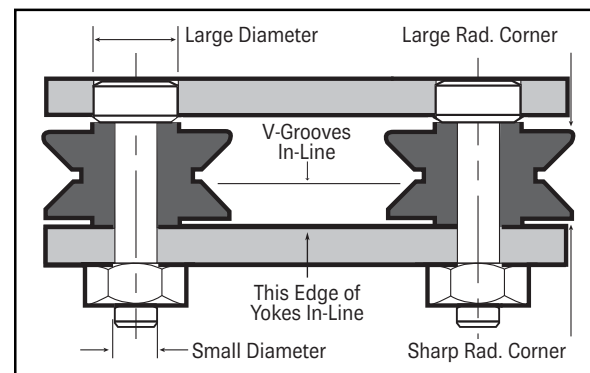

Hex Socket Sizes

Inch		Metric	
Stud Diameter	Hex Socket Size	Stud Diameter	Hex Socket Size
≤ 1/2"	3/16"	≤ 12 mm	4 mm
5/8" – 7/8"	5/16"	14 mm	6 mm
1" – 1 1/4"	1/2"	16 - 30 mm	8 mm
≥ 2"	5/8"	≥ 30 mm	12 mm

Load Runners

Fax/Email Quotation Form

PLR Plain Concentric

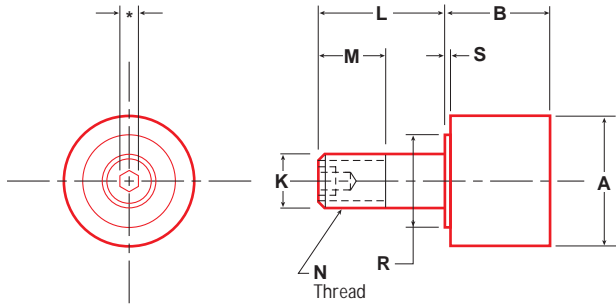

PLRE Plain Eccentric

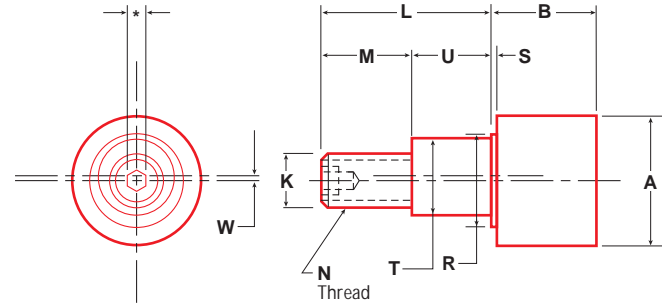

FLR Flanged Concentric

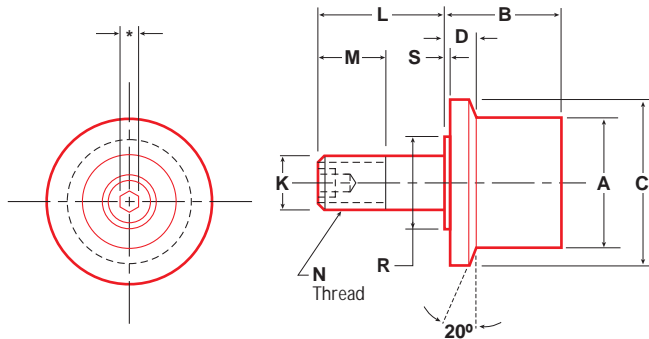

FLRE Flanged Eccentric

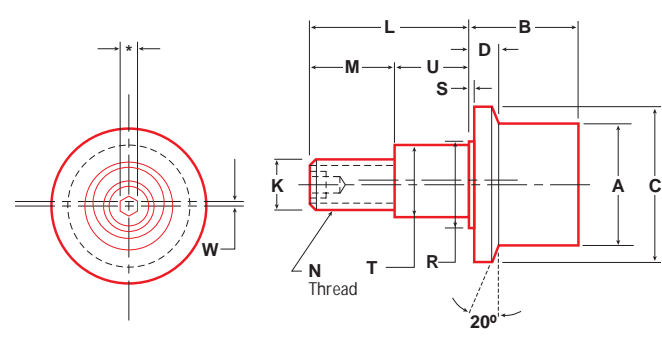

VLR V-Grooved Concentric

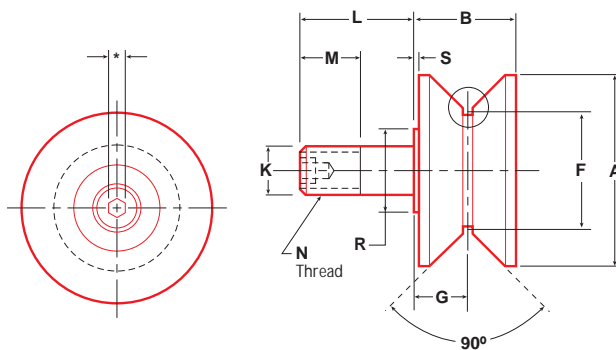

VLRE V-Grooved Eccentric

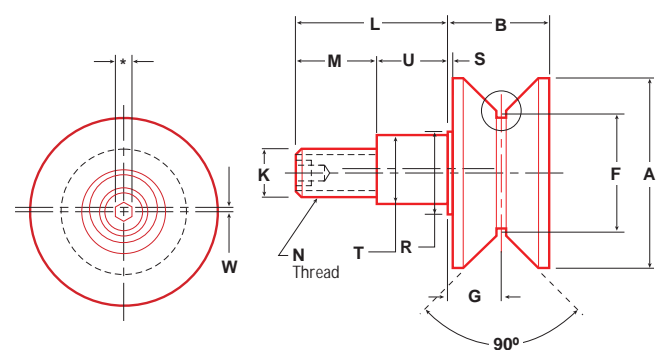

Name: _____	Operating Temperature: _____	A Roller Dia.
Company: _____	Loads: _____	B Roller Width
Address: _____	Speeds: _____	C Flange Dia.
Phone: _____	Desired L-10 Life: _____	D Flange Width
Application: _____	Lubrication:	F Point Dia.
_____	<input type="checkbox"/> Sealed <input type="checkbox"/> Solid Lub. <input type="checkbox"/> Manual	G Groove Loc.
_____	Material:	K Stud Dia.
_____	<input type="checkbox"/> Steel <input type="checkbox"/> Stainless <input type="checkbox"/> Other _____	L Stud Length
Critical Dimensions: _____		M Thread Len.
_____		N Thread
		R Shoulder Dia.
		S Shoulder Len.
		T Eccent. Dia.
		U Eccent. Len.
		W Eccentricity

FAX TO 216-361-1606

FFLR Double Flanged Concentric

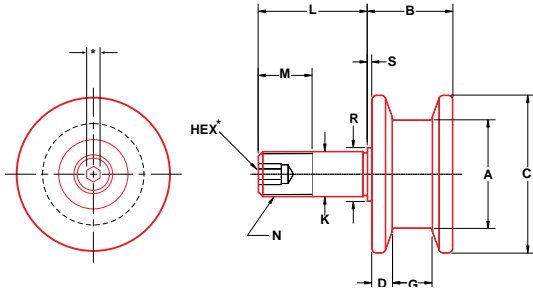

PLRY Plain Yoke Style

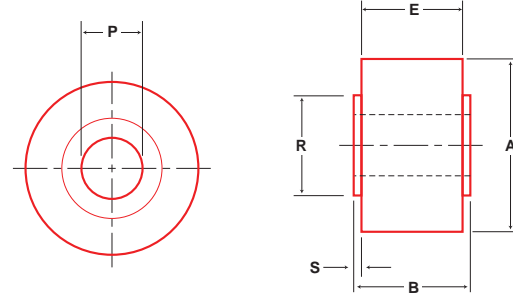

SHA Concentric Yoke Shaft

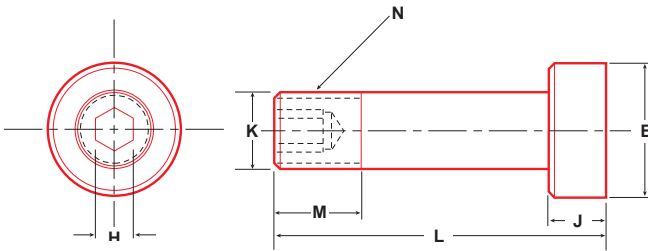

FLRY Flanged Yoke Style

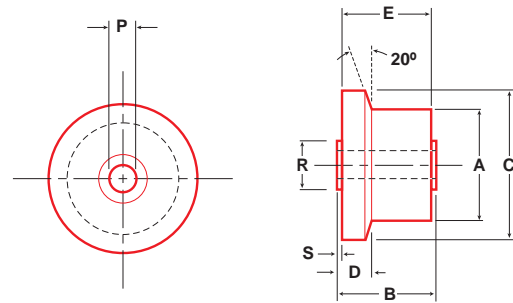

SHE Eccentric Yoke Shaft

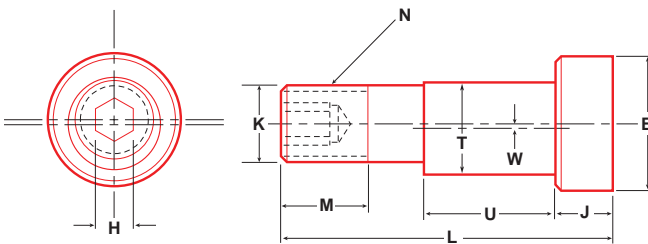

VLRY V-Grooved Yoke Style

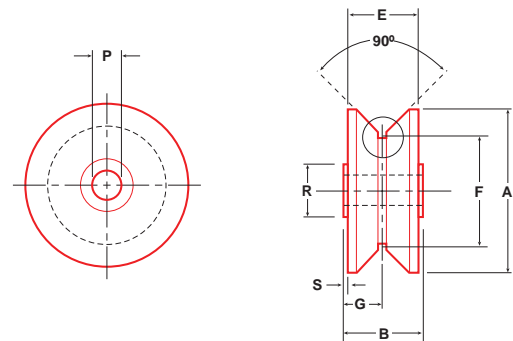

Idler Rollers are not recommended for repetitive and/or impact loads. Shock and impact loads will reduce the life of the roller.

Name: _____	Operating Temperature: _____	A Roller Dia.
Company: _____	Loads: _____	B Roller Width
Address: _____	Speeds: _____	C Flange Dia.
Phone: _____	Desired L-10 Life: _____	D Flange Width
Application: _____	Lubrication:	F Point Dia.
_____	[] Sealed [] Solid Lub. [] Manual	G Groove Loc.
_____	Material:	K Stud Dia.
_____	[] Steel [] Stainless [] Other _____	L Stud Length
	Critical Dimensions: _____	M Thread Len.
		N Thread
		R Shoulder Dia.
		S Shoulder Len.
		T Eccent. Dia.
		U Eccent. Len.
		W Eccentricity

FAX TO 216-361-1606



**Load
Runners®**

OSBORN Load Runners

Tel.: 1 (800) 720 5248 • Fax: 1 (216) 361 1606 • rollers@osborn.com • www.loadrunners.com • A unit of Jason, Inc.
©Osborn 2014. All rights reserved. LIT12500 D5K2014-2