

8 7 6 5 4 3 2 1

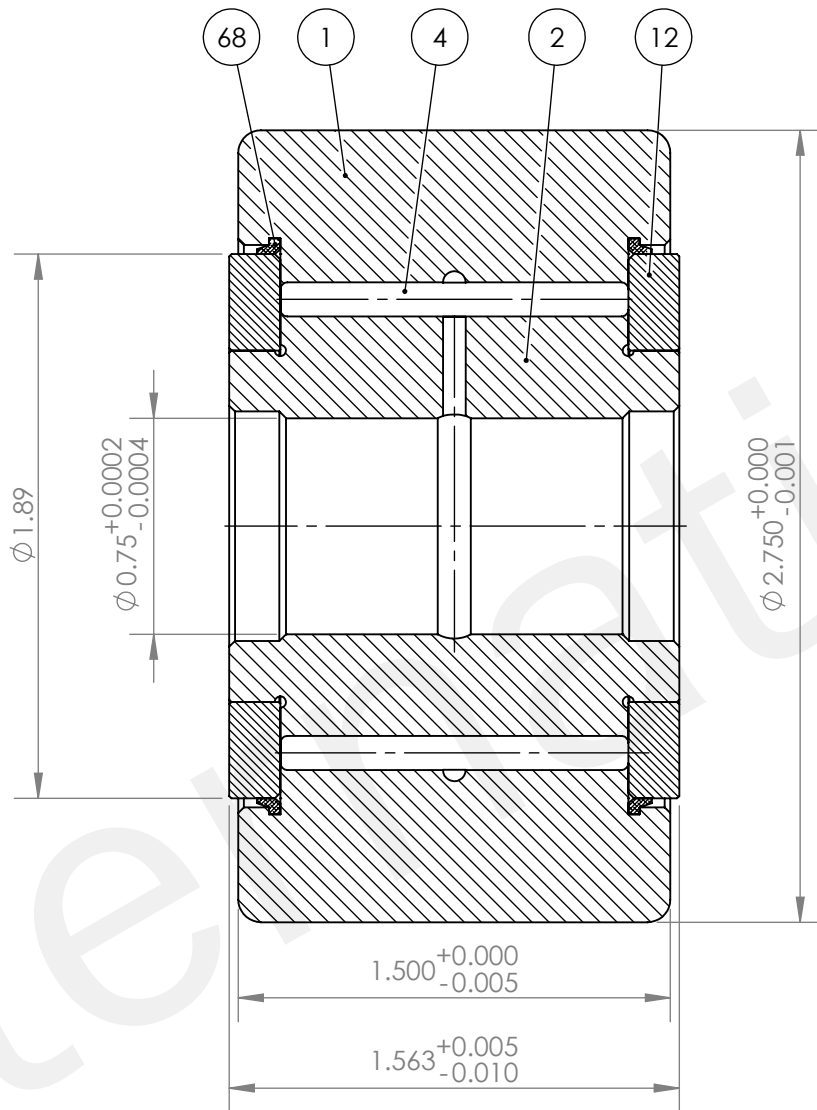

SECTION A-A

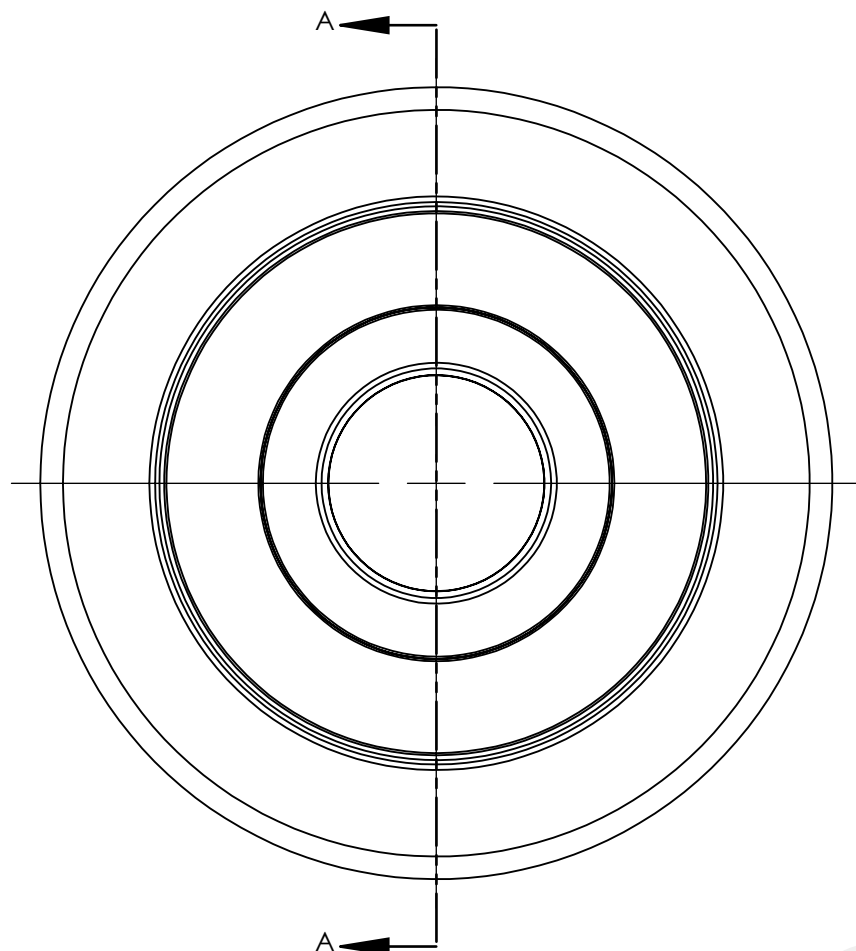
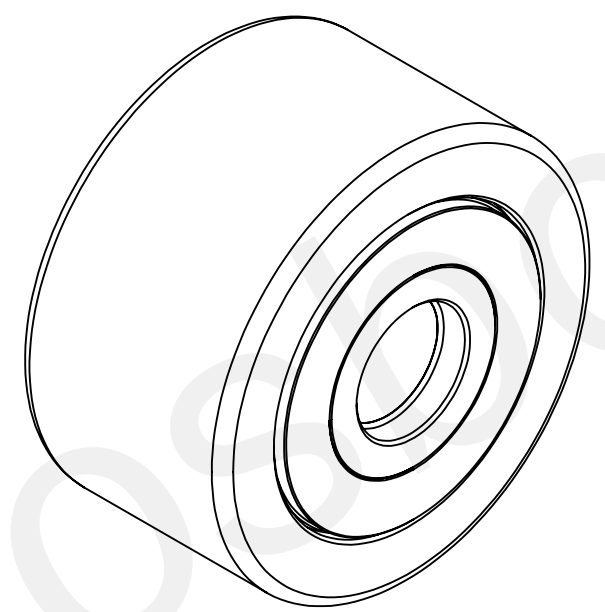

68	SEAL RING	2
12	LOOSE RIB	1
04	NEEDLE ROLLER (P4.54X27.8)	27
02	INNER RING	1
01	OUTER RING	1
NO.	NAME	QTY

<p>Notes:</p> <ol style="list-style-type: none"> Rated load: Cr =66.1 KN, Cor=111.8 KN ; Radial internal clearance: 0.020-0.045mm ; Bearing surface blackening treatment: Grease: Shell Grease ; Shape location tolerance should be to current standard. 					<p>Units are in Inches ASME Y14.5</p> <p>X.X ± 0.040 X.XX ± 0.015 X.XXX ± 0.005 X.XXXX ± 0.0005</p>		<p>Third Angle Projection</p>		<p>State: Approval Pending</p> <p>QTY: Scale: 3:2</p>	
<p>Passing on and copying of this document, use and its contents is not permitted unless expressly permitted. Violators are liable for damages. All rights for the Case of patent award or utility model registration. (DIN34/ISO16016)</p> <p>Weitergabe sowie Vervielfältigung dieser Unterlage, Verwertung und Mitteilung ihres Inhalts nicht gestattet, soweit nicht ausdrücklich erlaubt. Zuwiderhandlungen verpflichten zu Schadensersatz. Alle Rechte für den Fall der Patenterteilung oder Gebrauchsmuster-Eintragung vorbehalten. (DIN34/ISO16016)</p>					<p>Date Name</p> <p>Drawn 2016/10/19 AS</p> <p>Check - -</p> <p>Aprv - -</p>		<p>Hardness: - HRC</p> <p>Name / Title: YOKE TYPE TRACK ROLLER BEARING</p> <p>Mat'l Dims: CYR 2-3/4 S</p> <p>Description: SEALED</p>		<p>Machine Name: - Machine No: -</p> <p>Tool Name: - Tool No: -</p>	
<p>Department LoadRunner</p>							<p>Drawing Number: 0009221800</p> <p>SAP Part Number: -</p> <p>Replacement for: - Replaced by: -</p>		<p>Sheet Size ANSI B 1 of 1</p>	
Rev	ECN	Description	Date	Name	Made From:-					

8 7 6 5 4 3 2 1