

8 7 6 5 4 3 2 1

D
C
B
A

D
C
B
A

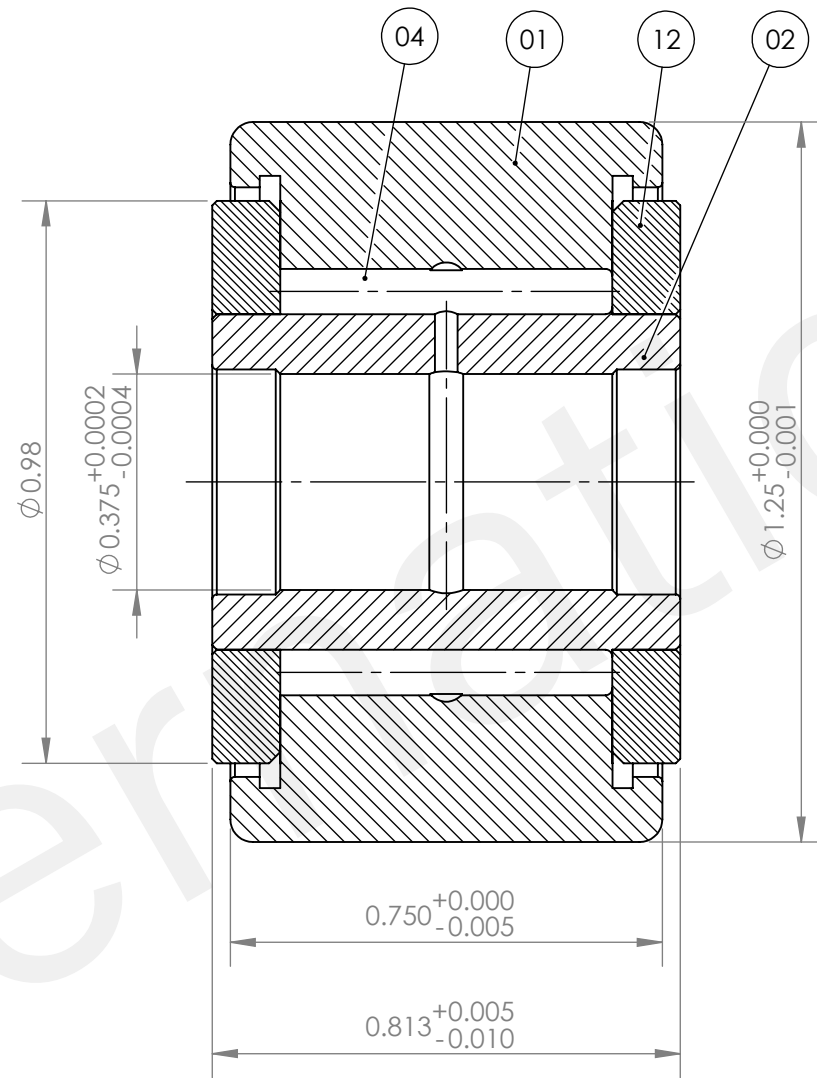
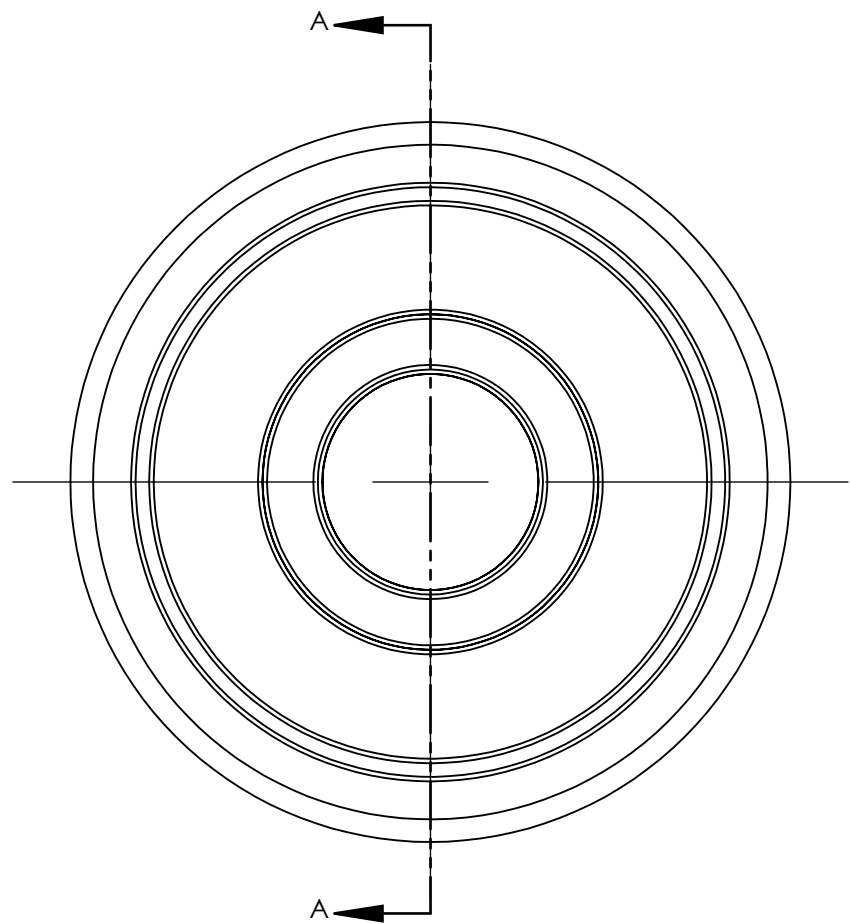

SECTION A-A

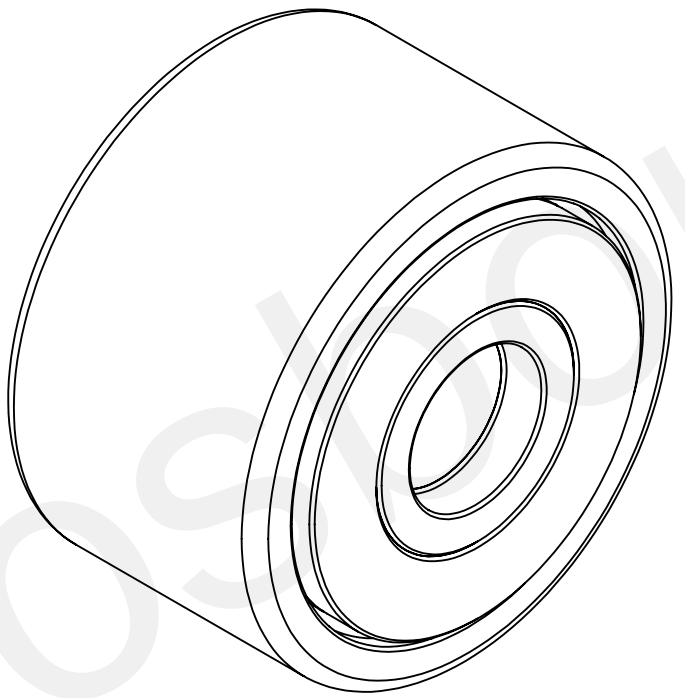

NO.	NAME	QTY
12	LOOSE RIB	1
04	NEEDLE ROLLER (P2.5X12.8)	23
02	INNER RING	1
01	OUTER RING	1

Notes:
 1. Rated load: Cr =15.5 KN, Cor=20.6 KN ;
 2. Radial internal clearance: 0.020-0.045mm ;
 3. Bearing surface blackening treatment:
 4. Grease: Shell Grease ;
 5. Shape location tolerance should be to current standard.

Units are in Inches
 ASME Y14.5
 X.X ± 0.040
 X.XX ± 0.015
 X.XXX ± 0.005
 X.XXXX ± 0.0005

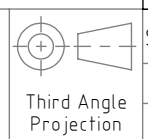

State: Approval Pending	QTY:	Scale: 3:1
Material:	-	
Finish:	-	
Hardness:	- HRC	
Name / Title:	YOKE TYPE TRACK ROLLER BEARING	
Mat'l Dims:	CYR 1-1/4	
Description:	NO SEALS	
Machine Name:	-	Machine No: -
Tool Name:	-	Tool No: -
Drawing Number:	0009220400	Sheet Size ANSI B 1 of 1
SAP Part Number:	-	
Replacement for:-		Replaced by:-

Passing on and copying of this document, use and its contents is not permitted unless expressly permitted. Violators are liable for damages. All rights for the Case of patent award or utility model registration. (DIN34/ISO16016)

Weitergabe sowie Vervielfältigung dieser Unterlage, Verwertung und Mitteilung ihres Inhalts nicht gestattet, soweit nicht ausdrücklich erlaubt. Zuwiderhandlungen verpflichten zu Schadenersatz. Alle Rechte für den Fall der Patenterteilung oder Gebrauchsmuster-Eintragung vorbehalten. (DIN34/ISO16016)

Rev	ECN	Description	Date	Name	Made From:-
-	-	-	-	-	-
-	-	-	-	-	-
+	-	Initial Release	-	-	-



8 7 6 5 4 3 2 1