

8 7 6 5 4 3 2 1

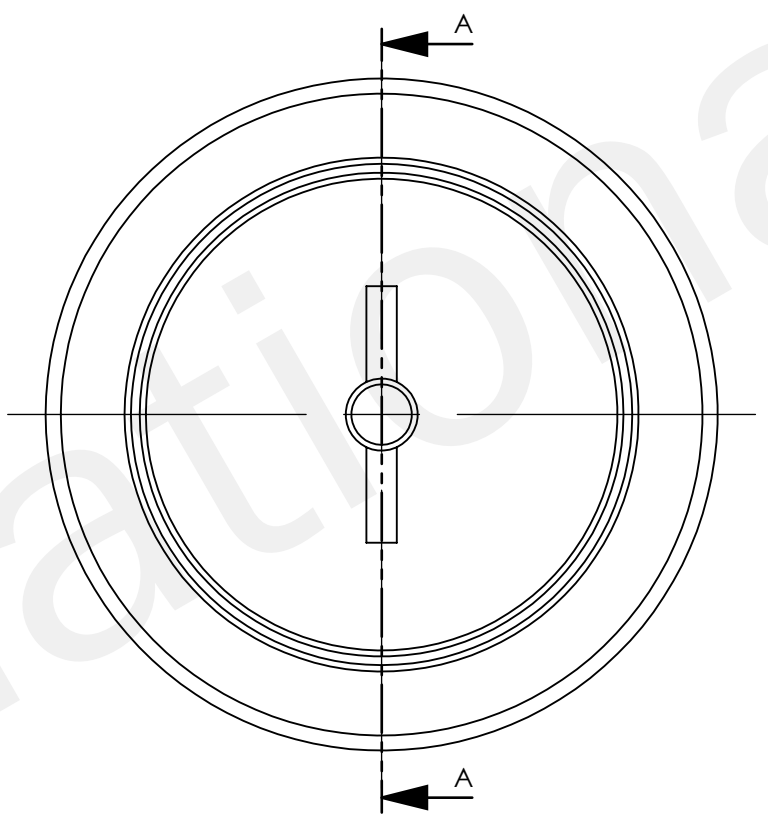

SECTION A-A

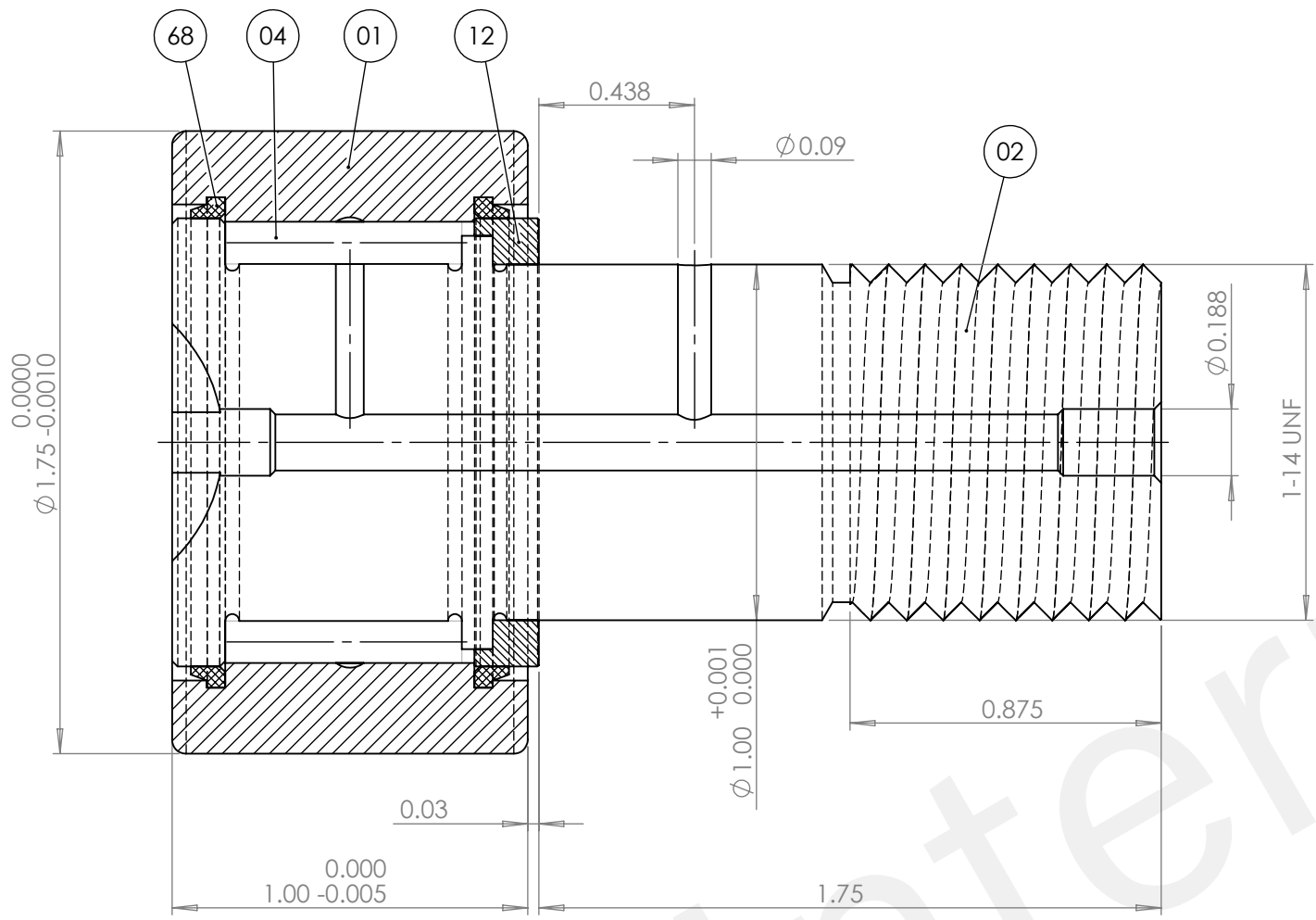
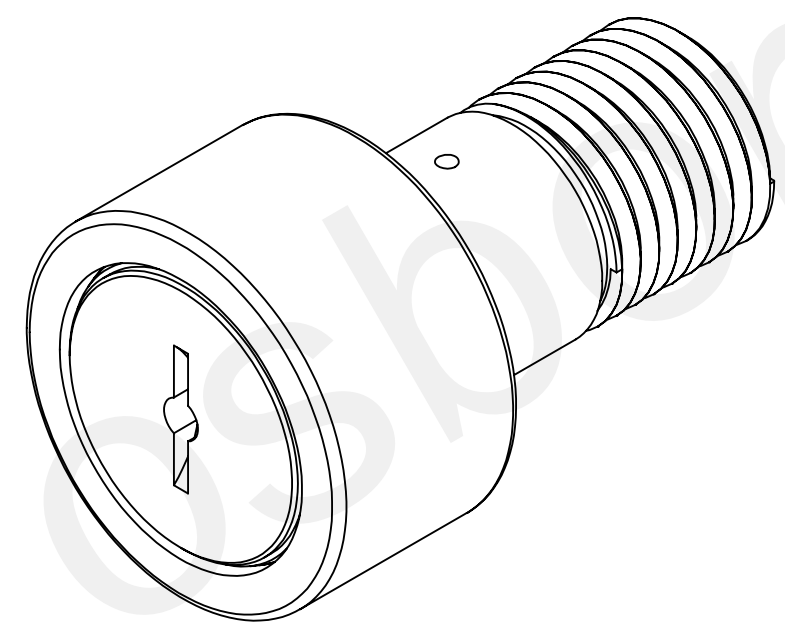

| NO. | NAME | QTY |
|-----|---------------------------|-----|
| 68 | SEAL RING | 2 |
| 12 | LOOSE RIB | 1 |
| 04 | NEEDLE ROLLER (P2.5X16.8) | 33 |
| 02 | SHAFT | 1 |
| 01 | OUTER RING | 1 |

Notes:
 1. Rated Load: Cr=25.5 KN, Cor=44.1 KN
 2. Radial internal clearance: 0.020-0.045mm
 3. Bearing surface Black oxidation
 4. Grease: shell Grease
 5. Shape location Tolerance should be to current standard.

Units are in Inches
 ASME Y14.5
 X.X ± 0.040
 X.XX ± 0.015
 X.XXX ± 0.005
 X.XXXX ± 0.0005

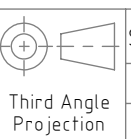

| | | |
|--|----------------|--------------------------|
| State: Approval Pending | QTY: | Scale: 2:1 |
| Material: - | | |
| Finish: - | | |
| Hardness: - HRC | | |
| Name / Title: STUD TYPE TRACK ROLLER BEARING | | |
| Mat'l Dims: CFH 1-3/4 S | | |
| Description: HD w/Seals | | |
| Machine Name: - | Machine No: - | |
| Tool Name: - | Tool No: - | |
| Drawing Number: 0009216900 | | Sheet Size ANSI B 1 of 1 |
| SAP Part Number: - | | |
| Replacement for: - | Replaced by: - | |

Passing on and copying of this document, use and its contents is not permitted unless expressly permitted. Violators are liable for damages. All rights for the Case of patent award or utility model registration. (DIN34/ISO16016)

Weitergabe sowie Vervielfältigung dieser Unterlage, Verwertung und Mitteilung ihres Inhalts nicht gestattet, soweit nicht ausdrücklich erlaubt. Zuwiderhandlungen verpflichten zu Schadenersatz. Alle Rechte für den Fall der Patenterteilung oder Gebrauchsmuster-Eintragung vorbehalten. (DIN34/ISO16016)

| Rev | ECN | Description | Date | Name | Made From:- |
|-----|-----|-----------------|------|------|-------------|
| - | - | - | - | - | - |
| - | - | - | - | - | - |
| + | - | Initial Release | - | - | - |

